

FOREWORD

This Parts Catalogue is related to the parts in use for the Yamaha AG200FU(3GX1)/AG200L(36X). When you are ordering replacement parts for the AG200FU(3GX1)/AG200L(36X), refer to this Parts Catalogue and quote both part numbers and part names correctly.

1. Modifications or additions which have been made after issue of the Parts Catalogue will be announced in the Yamaha Parts News.
It is advisable that according to the Yamaha Parts News you make necessary corrections to the Parts Catalogue on hand to keep it up-to-date.

2. Abbreviations

The following abbreviations are used in this Parts Catalogue.

- U.R. Use size (thickness) and/or number as required.
- U.N. Use as many as you need.
- A.P. Alternate Parts
- L.M. Local Made
- F# Frame No. (Applicable machine No.)

3. The parts marked with (+) in the parts number column of this Catalogue are not supplied with by Yamaha, those have to be found locally.
4. Parts, which are to be supplied in the form of assemblies, are listed with an indentation of one letter's space, and a dot (.) is put against the name of each part.

EXAMPLE CARBURETOR ASS'Y
 . JET, pilot
 . NOZZLE, main

5. Indication of No. of constituent parts for assembly

The numeral appearing to the right of each constituent part under the description indicates the quantity of such parts for each individual assembly unit.

EXAMPLE

Part No.	Description	Q'ty	Remarks
2F5-83310-60	FRONT FLASHER LIGHT ASS'Y	2	
115-83311-60	. BULB (6V-18W)	1	
1M1-83309-60	. REFLECTOR	1	

6. Initial Serial No. and Color Code

3GX1	(A) Frame Serial No.	3GX-000101 and following
	(B) Engine Serial No.	3GX-000101 and following

36X	(A) Frame Serial No.	36X-000101 and following
	(B) Engine Serial No.	36X-000101 and following

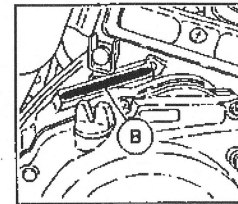
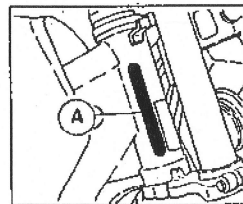

Color Code	Color Name	Abbreviate
26	COMPETITION YELLOW	CPY
TL	CERAMIC IVORY	CRI

7. Applicable colors of graphics are represented in the "Remarks" column by the letter(s) appropriately picked out of the full word(s) showing such colors.

EXAMPLE

Part No.	Description	Q'ty	Remarks
2N4-24110-00-X5	FUEL TANK COMP.	1	MAXIM RED
3J1-24240-10	. GRAPHIC, fuel tank set	1	for MXR

A4

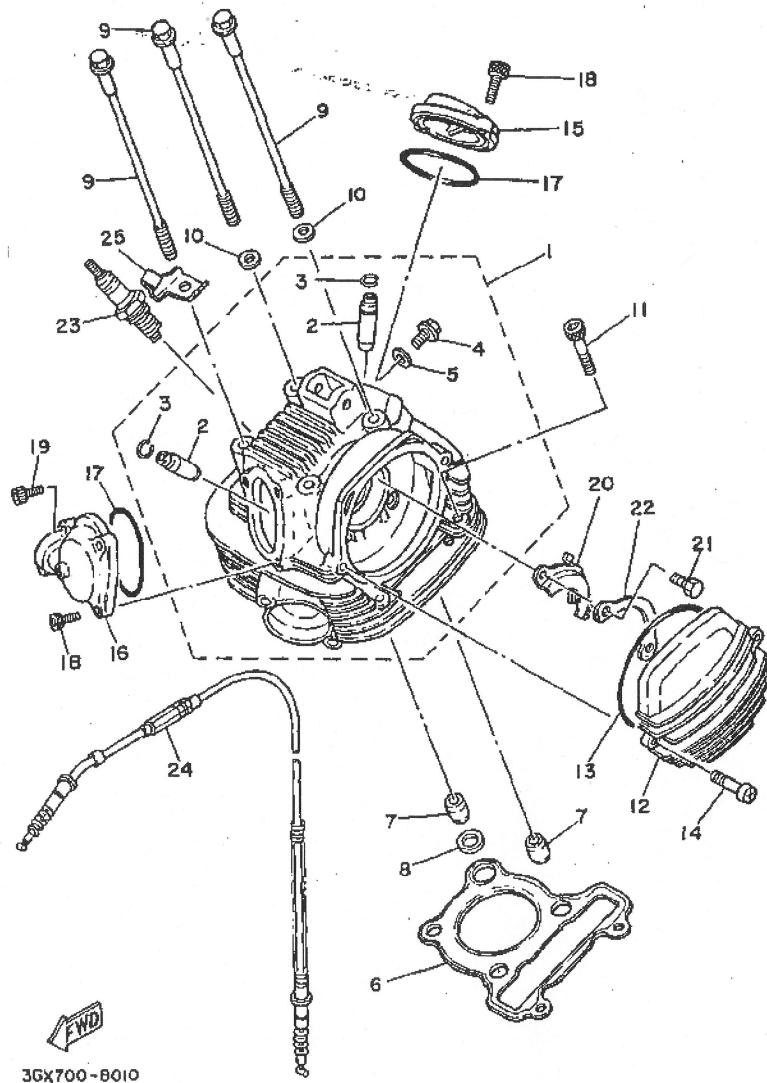
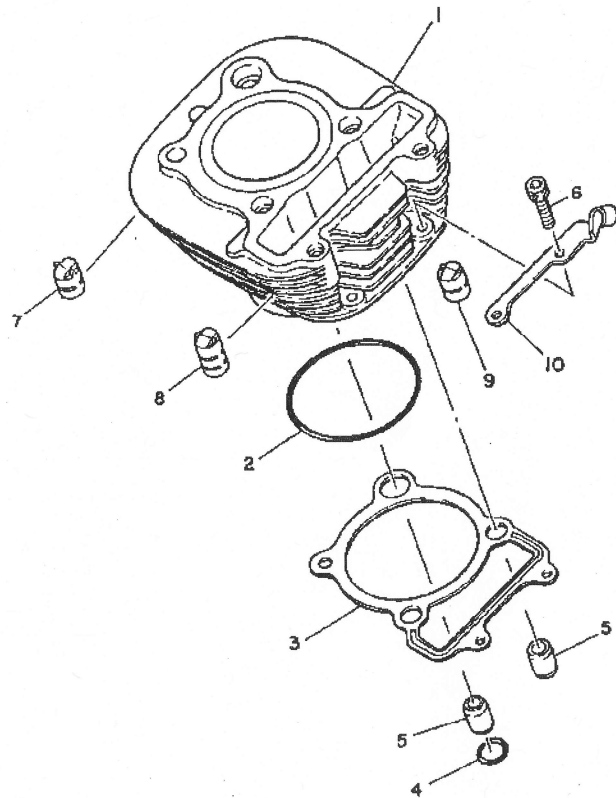

FIG. 1 CYLINDER HEAD

REF. NO.	PART NO.	DESCRIPTION	Q'TY	REMARKS
1	36X-11110-00	CYLINDER HEAD ASSY	1	
2	5H0-11133-10	.GUIDE, Intake valve	2	
3	93440-10085	.CIRCLIP	2	
4	90153-06045	.SCREW, hexagon	1	
5	90430-06014	.GASKET	1	
6	1N0-11181-00	GASKET, cylinder head 1	1	
7	99530-14016	PIN, dowel	3	
8	90430-14131	GASKET	1	
9	90105-08195	BOLT, washer based	4	
10	90201-080L7	WASHER, plate	3	
11	91311-08045	BOLT	2	
12	36X-11185-00	COVER, cylinder head side 1	1	
13	93211-05471	O-RING	1	
14	92501-06020	SCREW, pan head	2	
15	5H0-11186-00	COVER, cylinder head side 2	1	
16	36X-11187-00	COVER, cylinder head side 3	1	
17	93210-57634	O-RING	2	
18	91311-06018	BOLT	4	
19	90110-06064	BOLT, hexagon socket head	1	
20	5H0-11171F-00	PLATE	1	
21	97013-06012	BOLT	2	
22	90215-06184	WASHER, lock	1	
23	94701-00157	PLUG, spark (NGK D8EA)	1	UR
	94701-00181	PLUG, spark (ND X24E5-U)	1	UR
24	36X-12292-00	CABLE, decompression	1	
25	36X-12283-00	BRACKET, decompression	1	

B2

FIG. 2 CYLINDER



REF. NO.	PART NO.	DESCRIPTION	Q'TY	REMARKS
1	36X-11310-00	CYLINDER	1	
2	93210-72529	O-RING	1	
3	15A-11351-00	GASKET, cylinder	1	
4	93210-13361	O-RING	1	
5	99530-14016	PIN, dowel	2	
6	91311-06030	BOLT	2	
7	15A-11162-00	ABSORBER 2	2	
8	5H0-11161-00	ABSORBER 1	2	
9	15A-11162-00	ABSORBER 2	1	
10	15A-15441-00	HOLDER, clutch cable	1	



36X700-3020

B3

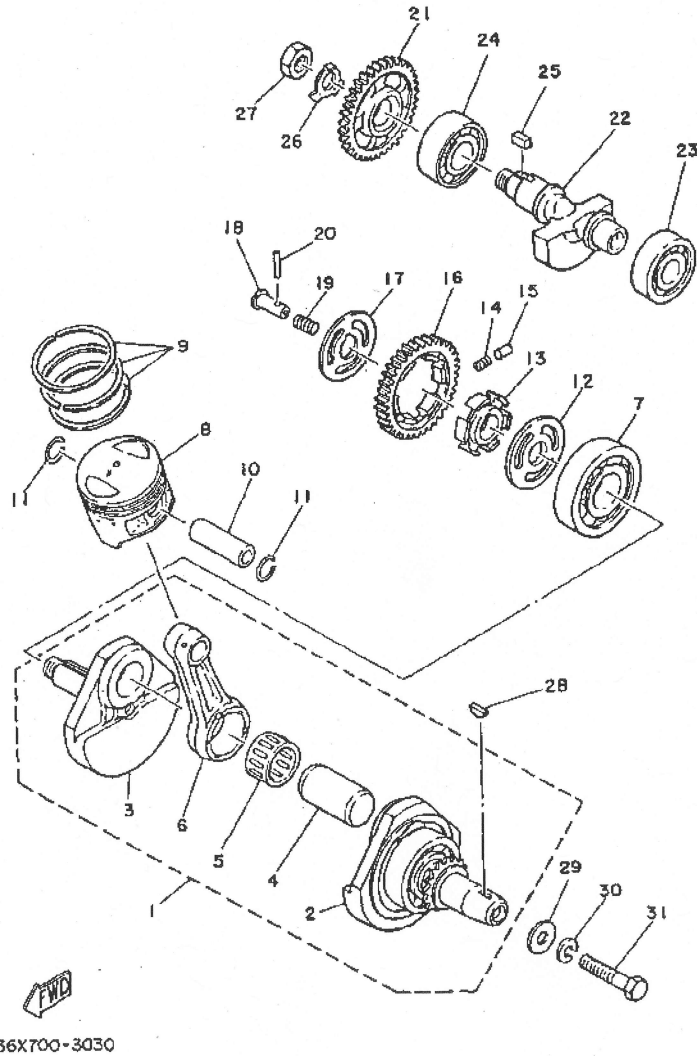
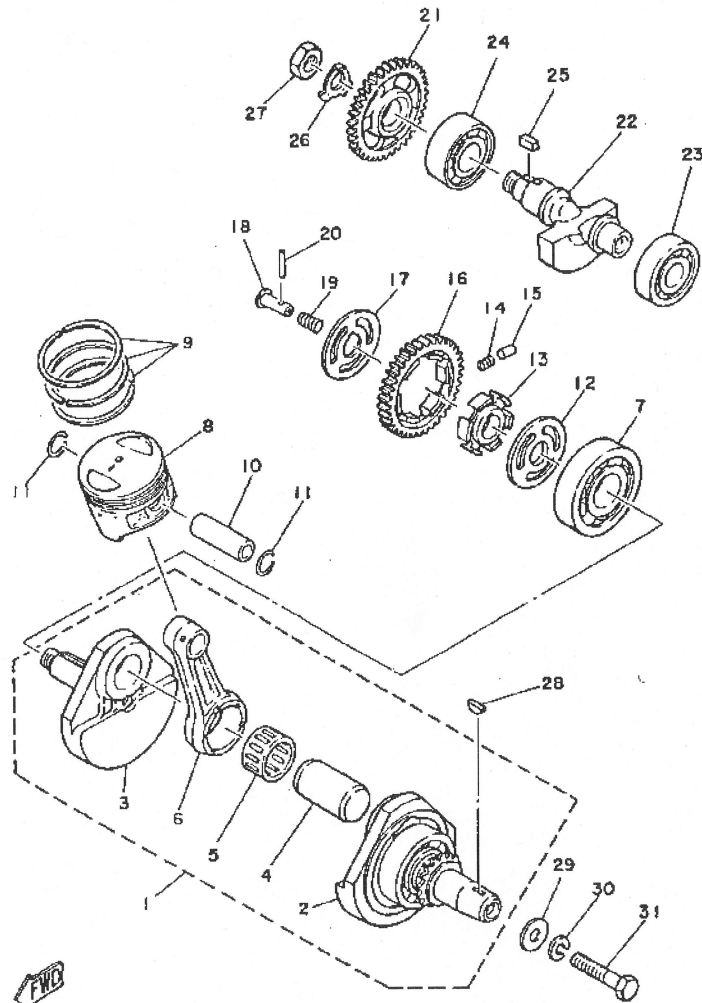

FIG. 3 CRANKSHAFT. PISTON

REF. NO.	PART NO.	DESCRIPTION	Q'TY	REMARKS
1	15A-11400-00	CRANKSHAFT ASSY	1	
2	15A-11472-09	.CRANK 1	1	
3	5H0-11422-00	.CRANK 2	1	
4	5H0-11681-00	.PIN, crank 1	1	
5	93310-530J3	.BEARING, cylindrical	1	
6	15A-11651-00	.ROD, connecting	1	
7	93306-30615	BEARING (B6306)	1	
8	36X-11631-00-A0	PISTON (STD)	1	
	36X-11636-00	PISTON (0.50MM O/S)	1	AP
	36X-11638-00	PISTON (1.00MM O/S)	1	AP
9	15A-11610-00	PISTON RING SET (STD)	1	
	15A-11610-20	PISTON RING SET (2ND O/S)	1	AP
	15A-11610-40	PISTON RING SET (4TH O/S)	1	AP
10	58L-11633-00	PIN, piston	1	
11	93450-17044	CIRCLIP	2	
12	90201-201E4	WASHER, plate	1	
13	5H0-11496-00	BOSS, buffer	1	
14	90501-21133	SPRING, compression	6	
15	93605-10090	PIN, dowel	3	
16	5H0-11536-00	GEAR, drive (38T)	1	
17	90214-20023	WASHER, claw	1	
18	90240-07083	PIN, clevis	1	
19	90501-07629	SPRING, compression	1	
20	93602-13177	PIN, dowel	1	
21	5H0-11531-00	GEAR, balance weight (36T)	1	
22	15A-11454-00	WEIGHT 1	1	
23	93306-30427	BEARING	1	
24	93306-30427	BEARING	1	

B4



36X700-3030

FIG. 3 CRANKSHAFT, PISTON

REF. NO.	PART NO.	DESCRIPTION	Q'TY	REMARKS
25	90282-05013	KEY, straight	1	
26	90215-14205	WASHER, lock	1	
27	90170-14284	NUT	1	
28	90280-05013	KEY, woodruff	1	
29	90201-10508	WASHER, plate	1	
30	92901-10100	WASHER, spring	1	
31	90101-10188	BOLT	1	

B5

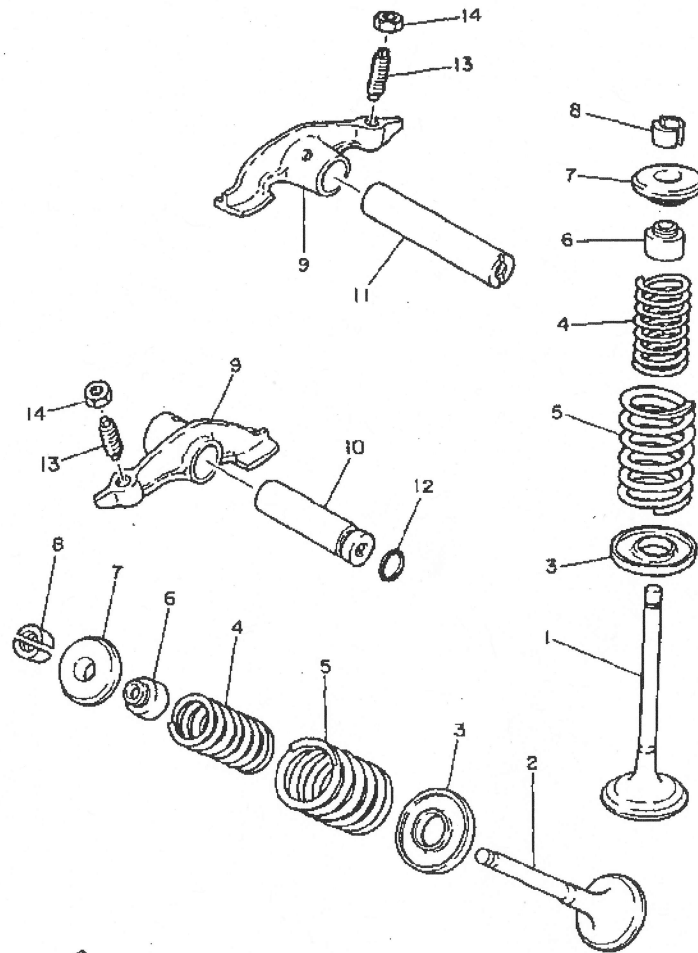

FIG. 4 VALVE

REF. NO.	PART NO.	DESCRIPTION	Q'TY	REMARKS
1	5H0-12111-00	VALVE, intake	1	
2	5H0-12121-00	VALVE, exhaust	1	
3	4G0-12116-01	SEAT, valve spring	2	
4	4G0-12113-00	SPRING, valve inner	2	
5	4G0-12114-00	SPRING, valve outer	2	
6	5H0-12119-00	SEAL, valve stem	2	
7	4G0-12117-00	RETAINER, valve spring	2	
8	4G0-12118-00	COTTER, valve	4	
9	36X-12151-00	ARM, valve rocker	2	
10	5H0-12156-00	SHAFT, rocker 2	1	
11	5H0-12146-00	SHAFT, rocker	1	
12	93210-09350	Q-RING	1	
13	3Y1-12159-00	SCREW, valve adjusting	2	
14	90170-06128	NUT	2	



36X700-3040

B6

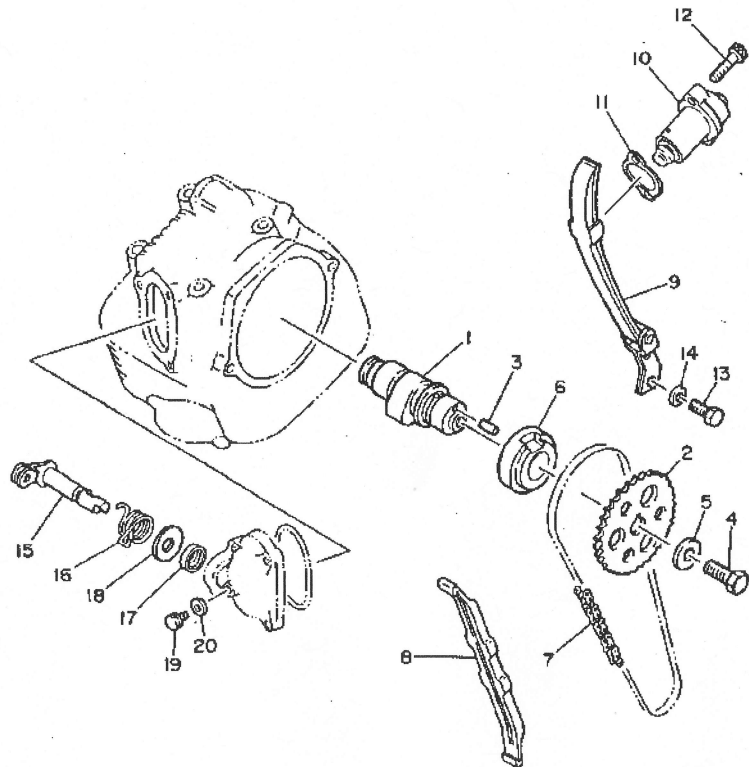

FIG. 5 CAMSHAFT. CHAIN

REF. NO.	PART NO.	DESCRIPTION	Q'TY	REMARKS
1	36X-12171-00	CAMSHAFT 1	1	
2	5N0-12176-00	SPROCKET, cam chain (40T)	1	
3	93604-10011	PIN, dowel	1	
4	90101-10303	BOLT	1	
5	90201-10774	WASHER, plate	1	
6	90387-255F3	COLLAR	1	
7	94580-41104	CHAIN	1	
8	5N0-12231-00	GUIDE, stopper 1	2	
9	5N0-12241-00	GUIDE, stopper 2	1	
10	2HT-12210-00	TENSIONER ASSY, cam chain	1	
11	30X-12213-00	GASKET, tensioner case	1	
12	91311-06025	BOLT	2	
13	97321-06016	BOLT	2	
14	92901-06600	WASHER, plate	2	
15	36X-12288-00	CAM, decompression	1	
16	90508-16428	SPRING, torsion	1	
17	93102-12106	OIL SEAL (SD T2-22-5 HS)	1	
18	90201-12588	WASHER, plate	1	
19	90109-06418	BOLT	1	
20	90430-06014	GASKET	1	



3GX700-8050

B7

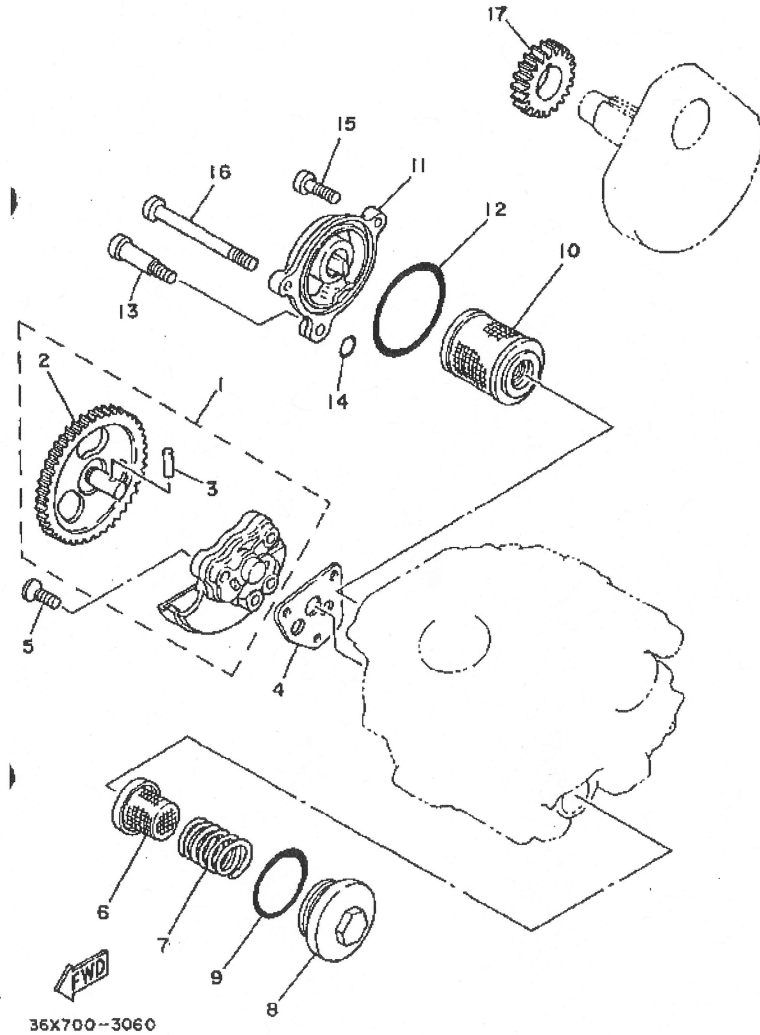

FIG. 6 OIL PUMP

REF. NO.	PART NO.	DESCRIPTION	Q'TY	REMARKS
1	5H0-13300-00	OIL PUMP ASSY	1	
2	5H0-13326-00	.GEAR, pump driven 2 (45T)	1	
3	93603-12030	.PIN, dowel	1	
4	5H0-13329-00	GASKET, pump cover	1	
5	92701-06030	SCREW, flat head	3	
6	3Y1-13411-00	STRAINER, oil	1	
7	90501-18576	SPRING, compression	1	
8	5H0-15351-00	PLUG, drain	1	
9	93210-35389	O-RING	1	
10	5H0-13440-00	ELEMENT ASSY, oil cleaner	1	
11	36X-13447-00	COVER, oil element	1	
12	93210-54175	O-RING	1	
13	90109-06755	BOLT	1	
14	93210-07135	O-RING	1	
15	92501-06025	SCREW, pan head	1	
16	92501-06075	SCREW, pan head	1	
17	36X-13324-00	GEAR, pump drive	1	

B8

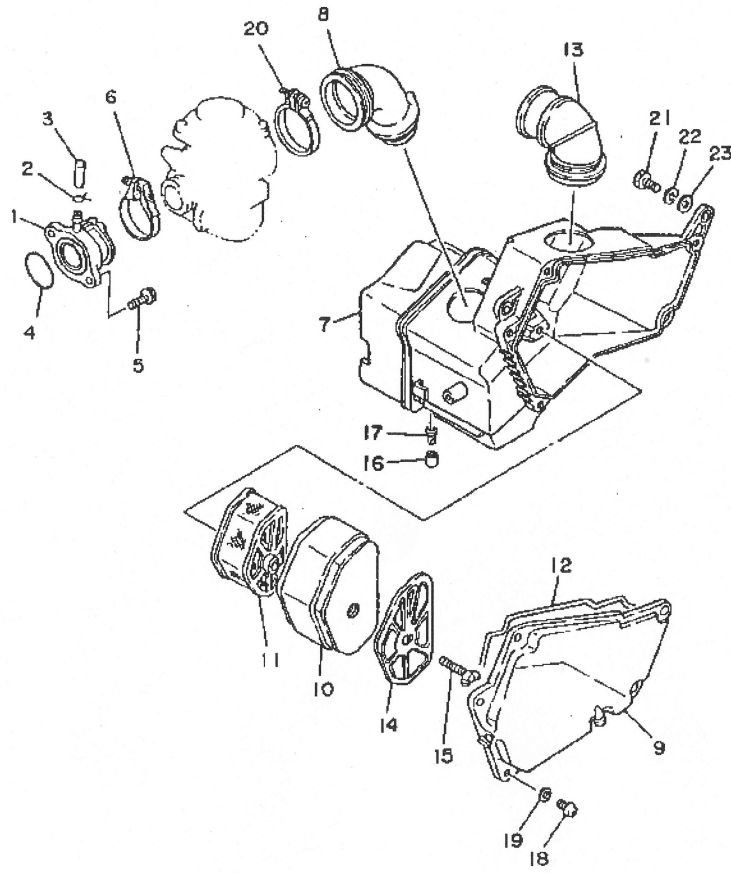

FIG. 7 INTAKE

REF. NO.	PART NO.	DESCRIPTION	Q'TY	REMARKS
1	36X-13586-00	JOINT, carburetor 1	1	
2	90467-10039	CLIP	1	
3	16G-13569-00	PLUG, blind	1	
4	93210-35537	O-RING	1	
5	91316-06020	BDLT	2	
6	1HX-13575-00	BAND	1	
7	36X-14401-00	AIR CLEANER CASE ASSY	1	
8	36X-14453-01	JDINT, air cleaner 1	1	
9	36X-14412-00	CAP, cleaner case 1	1	
10	36X-14451-00	ELEMENT, air cleaner	1	
11	36X-14458-00	GUIDE	1	
12	51Y-14462-00	SEAL	1	
13	36X-14437-00	DUCT	1	
14	36X-14468-00	PLATE, element fitting	1	
15	90122-06012	BOLT, wing	1	
16	90387-051K7	COLLAR	1	
17	24W-13512-00	VALVE, rotary	1	
18	98506-05016	SCREW, pan head	5	
19	92906-05600	WASHER, plate	5	
20	90460-56105	CLAMP, hose	1	
21	97011-06020	BOLT	2	
22	92990-06100	WASHER, spring	2	
23	92990-06200	WASHER, plain	2	

36X700-8070

B9

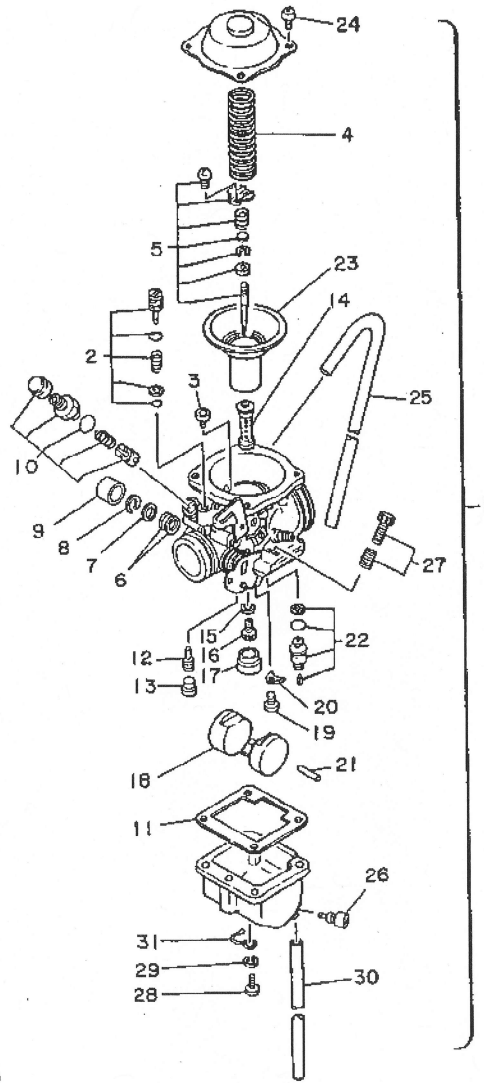

FIG. B CARBURETOR

REF. NO.	PART NO.	DESCRIPTION	Q'TY	REMARKS
1	36X-14901-00	CARBURETOR ASSY 1	1	
2	36X-14105-00	.PILOT SCREW SET	1	
3	3G2-14231-25	.JET, main (#125)	1	
4	36X-14933-01	.SPRING, diaphragm	1	
5	36X-1490J-00	.NEEDLE SET	1	
6	256-14997-00	.SEAL	2	
7	22F-14126-00	.GASKET	1	
8	812-14137-00	.CLIP	1	
9	36X-14169-00	.CAP	1	
10	36X-1410A-00	.STARTER SET	1	
11	4G0-14984-00	.GASKET, float chamber	1	
12	4G0-14142-35-A0	.JET, pilot (# 35)	1	
13	3F7-14991-00	.SCREW	1	
14	36X-14941-42	.NOZZLE, main	1	
15	137-14153-00	.WASHER, main jet	1	
16	620-14231-74-A0	.JET, main (#117.5)	1	
17	36X-14153-00	.WASHER, main jet	1	
18	4G0-14985-00	.FLOAT	1	
19	98501-04006	.SCREW, pan head	1	
20	36X-14146-00	.PLATE	1	
21	537-14186-00	.PIN, float	1	
22	256-14107-20	.NEEDLE VALVE SET	1	
23	36X-14940-00	.DIAPHRAGM ASSY	1	
24	98501-05008	.SCREW, pan head	4	
25	36X-14197-00	.PIPE	1	
26	36X-14191-00	.PLUG, drain	1	
27	36X-1490K-00	.STOP SCREW SET	1	
28	98503-04014	.SCREW, pan head	4	



36X700-3080

B10

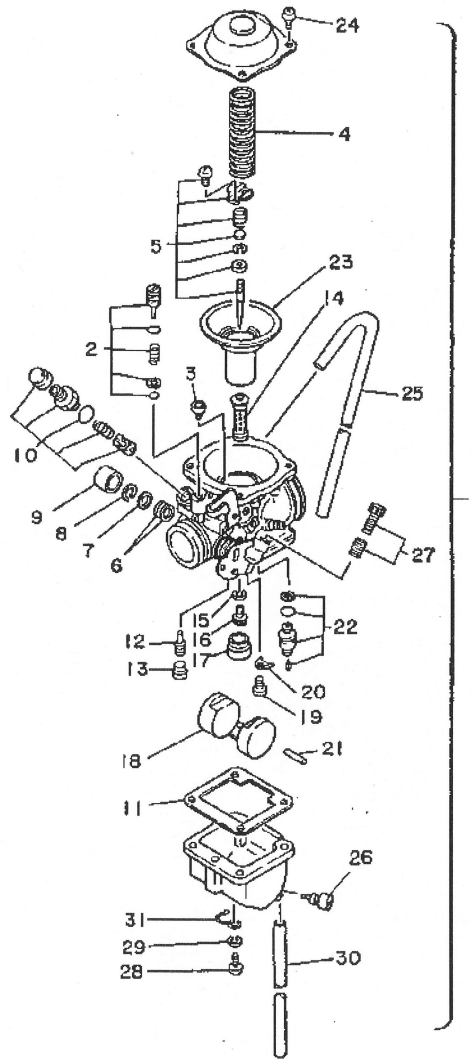

FIG. 8 CARBURETOR

REF. NO.	PART NO.	DESCRIPTION	Q'TY	REMARKS
29	92902-04100	.WASHER, spring	4	
30	21V-14196-00	.PIPE	1	
31	25G-14937-00	.CLIP	1	



36X700-3080

B11

10

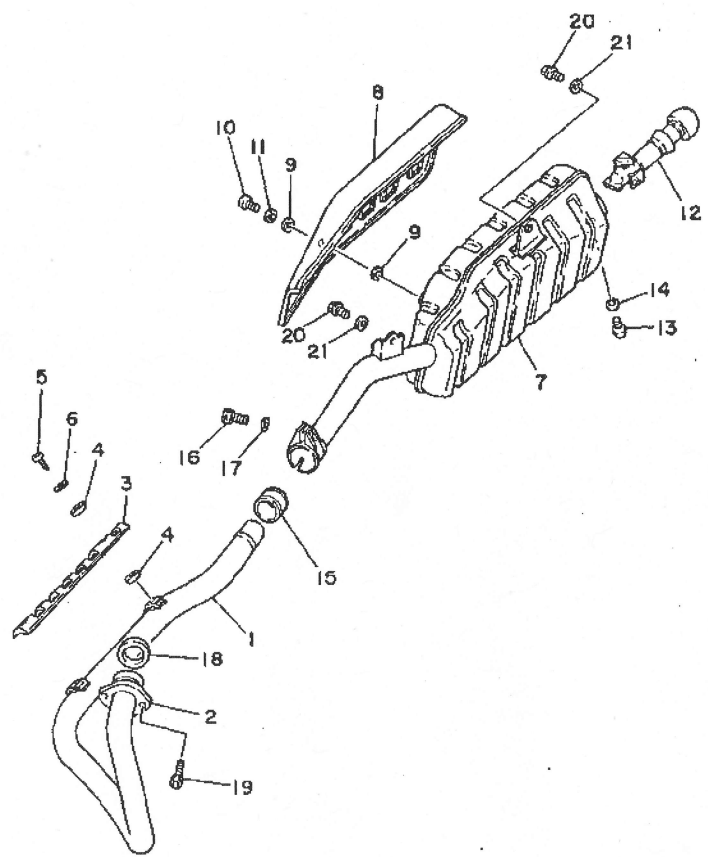

FIG. 9 EXHAUST

REF. NO.	PART NO.	DESCRIPTION	Q'TY	REMARKS
1	1FE-14611-00	PIPE, exhaust 1	1	
2	15A-14612-00	NUT, ring	1	
3	1FE-14628-00	PROTECTOR, exhaust pipe	1	
4	30X-14766-00	WASHER, protector	4	
5	90164-06077	SCREW, tapping	2	
6	90206-06060	WASHER, wave	2	
7	36X-14711-07	MUFFLER 1	1	
8	1FE-14728-00	PROTECTOR, muffler 2	1	
9	90202-06010	WASHER, plate	4	
10	98906-06010	SCREW, bind	2	
11	90206-06060	WASHER, wave	2	
12	36X-14752-01	PIPE, outlet	1	
13	92506-06008	SCREW, pan head	1	
14	92906-06100	WASHER, spring	1	
15	1JK-14714-00	GASKET, muffler	1	
16	91316-08025	BOLT	1	
17	92906-08600	WASHER, plate	1	
18	341-14613-00	GASKET, exhaust pipe	1	
19	91316-06020	BOLT	2	
20	90105-08141	BOLT, washer based	2	
21	90201-081H4	WASHER, plate	2	

3GX700-8090

B12

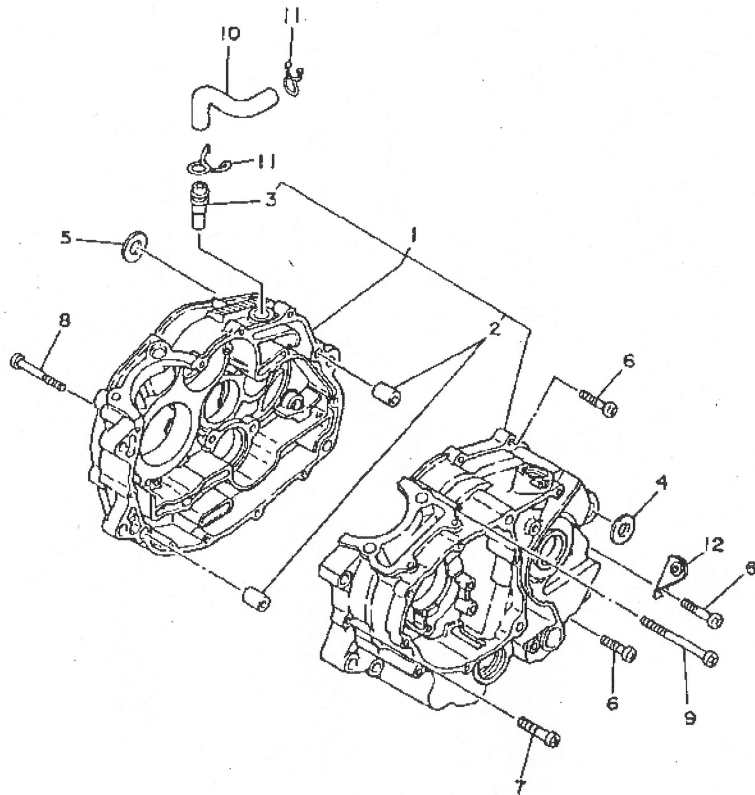

FIG. 10 CRANKCASE

REF. NO.	PART NO.	DESCRIPTION	Q'TY	REMARKS
1	36X-15100-01	CRANKCASE ASSY	1	
2	99510-12016	.PIN, dowel	2	
3	371-11167-01	.PIPE, breather 2	1	
4	90387-125F1	COLLAR	1	
5	90387-125F1	COLLAR	1	
6	92501-06030	SCREW, pan head	7	
7	92501-06040	SCREW, pan head	2	
8	92501-06080	SCREW, pan head	2	
9	92501-06085	SCREW, pan head	1	
10	36X-11166-00	PIPE, breather 1	1	
11	90467-14015	CLIP	2	
12	90465-03200	CLAMP	1	



36X700-8100

B13

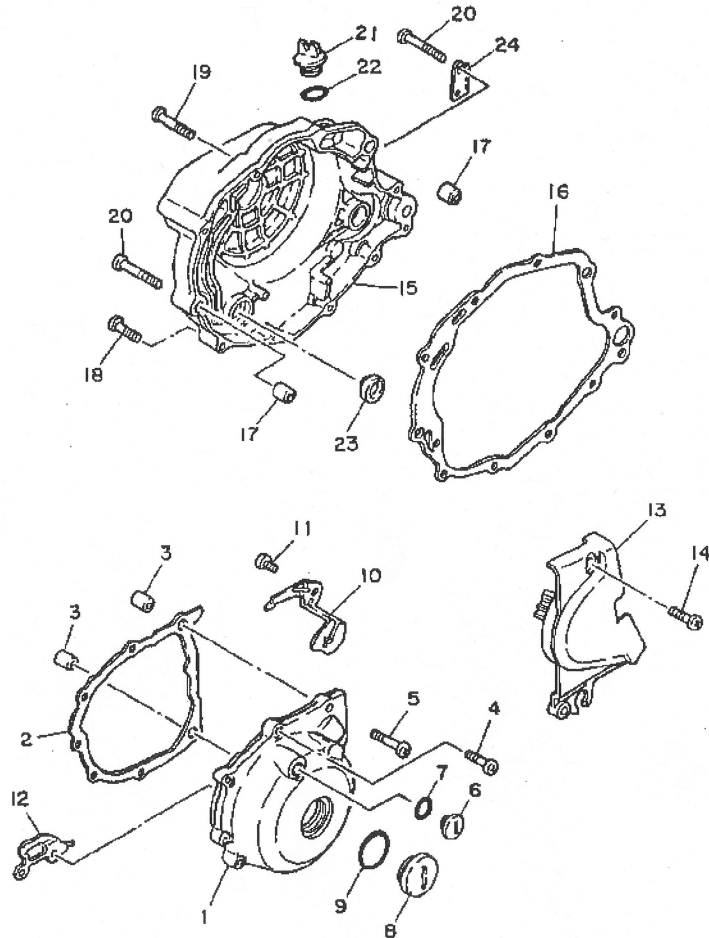

36X700-3110

FIG. 11 CRANKCASE COVER 1

REF. NO.	PART NO.	DESCRIPTION	Q'TY	REMARKS
1	36X-15411-00	COVER, crankcase 1	1	
2	15A-15451-00	GASKET, crankcase cover 1	1	
3	99510-12016	PIN, dowel	2	
4	92501-06025	SCREW, pan head	6	
5	92501-06035	SCREW, pan head	2	
6	90340-14068	PLUG, straight screw	1	
7	93210-14369	O-RING	1	
8	90340-32069	PLUG, straight screw	1	
9	93210-32172	O-RING	1	
10	90465-08188	CLAMP	1	
11	92501-06010	SCREW, pan head	1	
12	90465-16187	CLAMP	1	
13	36X-15421-00	COVER, crankcase 2	1	
14	92501-06025	SCREW, pan head	2	
15	36X-15431-00	COVER, crankcase 3	1	
16	15A-15462-00	GASKET, crankcase cover 3	1	
17	99510-12016	PIN, dowel	2	
18	92501-06025	SCREW, pan head	5	
19	92501-06035	SCREW, pan head	3	
20	92503-06045	SCREW, pan head	2	
21	1RG-15363-00	PLUG, oil	1	
22	93210-19123	O-RING	1	
23	3Y1-15361-00	GAUGE, level	1	
24	36X-15378-00	HOLDER	1	

B14

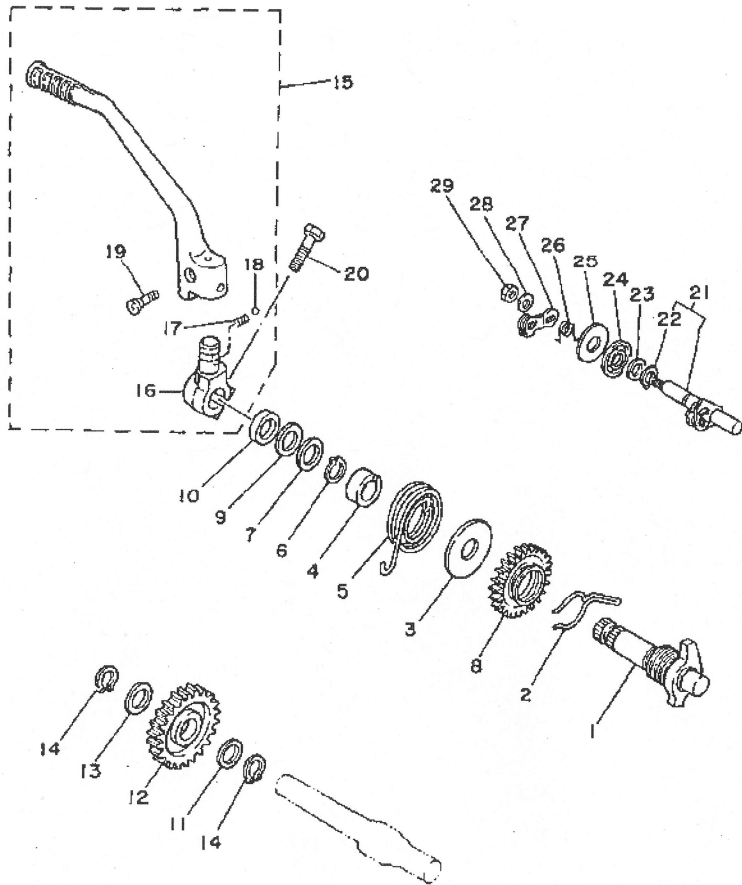

FWD
36X700-3120

FIG. 12 STARTER

REF. NO.	PART NO.	DESCRIPTION	Q'TY	REMARKS
1	36X-15660-01	KICK AXLE ASSY	1	
2	90460-26122	CLIP	1	
3	401-15676-00	COVER, spring	1	
4	15A-15666-00	SPACER	1	
5	90508-26538	SPRING, torsion	1	
6	99009-17400	CIRCLIP	1	
7	90201-175F6	WASHER, plate	1	
8	36X-15641-00	GEAR, kick	1	
9	90209-17226	WASHER	1	
10	93102-17263	OIL SEAL	1	
11	90201-173F4	WASHER, plate	1	
12	15A-15651-01	GEAR, kick idle (28T)	1	
13	90214-17028	WASHER, claw	1	
14	99009-17400	CIRCLIP	2	
15	36X-15620-01	KICK CRANK ASSY	1	
16	36X-15621-01	.BOSS, kick crank	1	
17	90501-12081	.SPRING, compression	1	
18	93507-32031	.BALL	1	
19	90157-06048	.SCREW, pan head	1	
20	97313-08030	BOLT	1	
21	36X-1561A-00	DECOMP. LEVER ASSY	1	
22	99009-10400	.CIRCLIP	1	
23	90201-10644	WASHER, plate	1	
24	93102-10207	OIL SEAL (SD 10-21-5 HS)	1	
25	90201-105J4	WASHER, plate	1	
26	90508-14620	SPRING, torsion	1	
27	36X-1561G-00	LEVER, cable	1	
28	92901-06600	WASHER, plate	1	

B15

FIG. 12 STARTER

REF. NO.	PART NO.	DESCRIPTION	Q'TY	REMARKS
29	95311-06700	NUT	1	

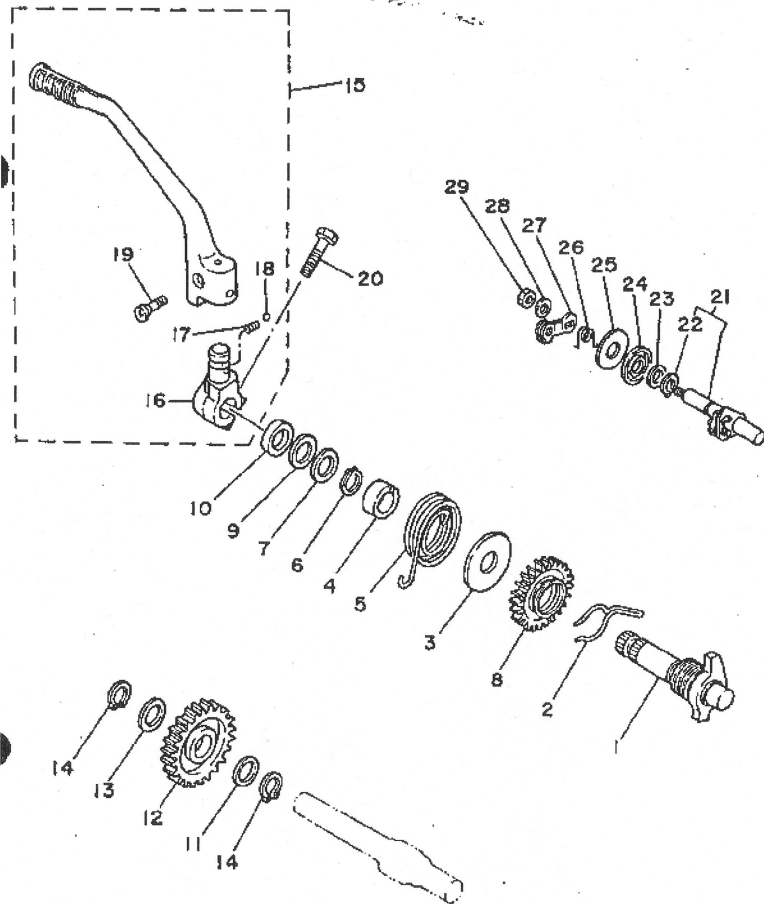

36X700-3120

C2

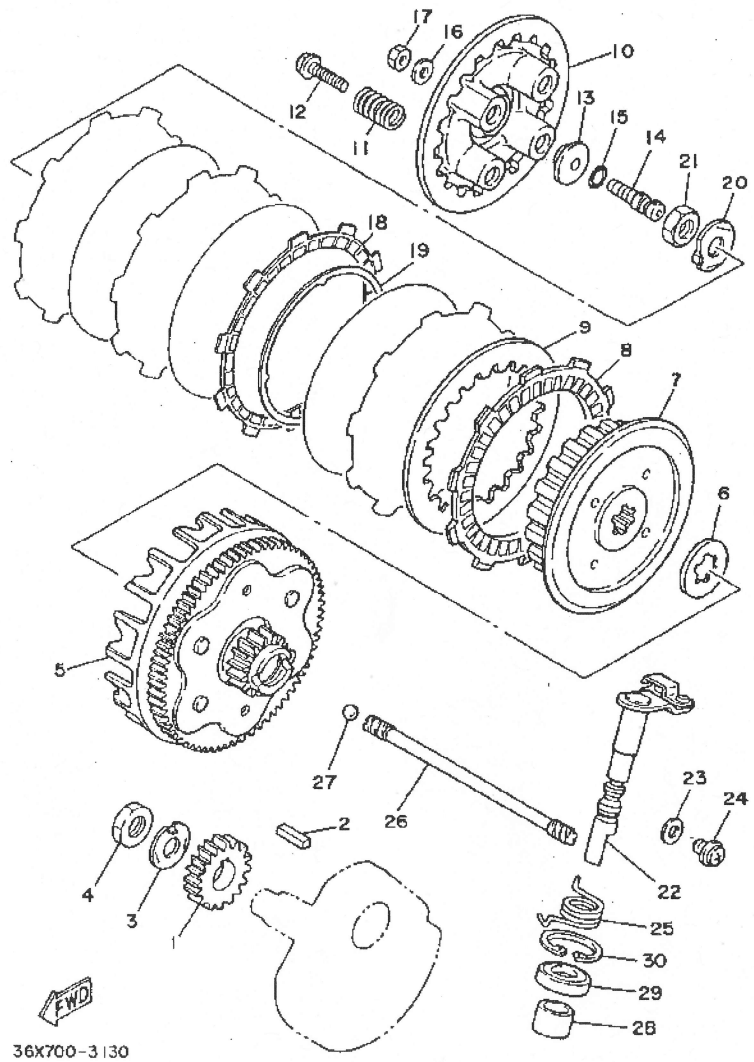
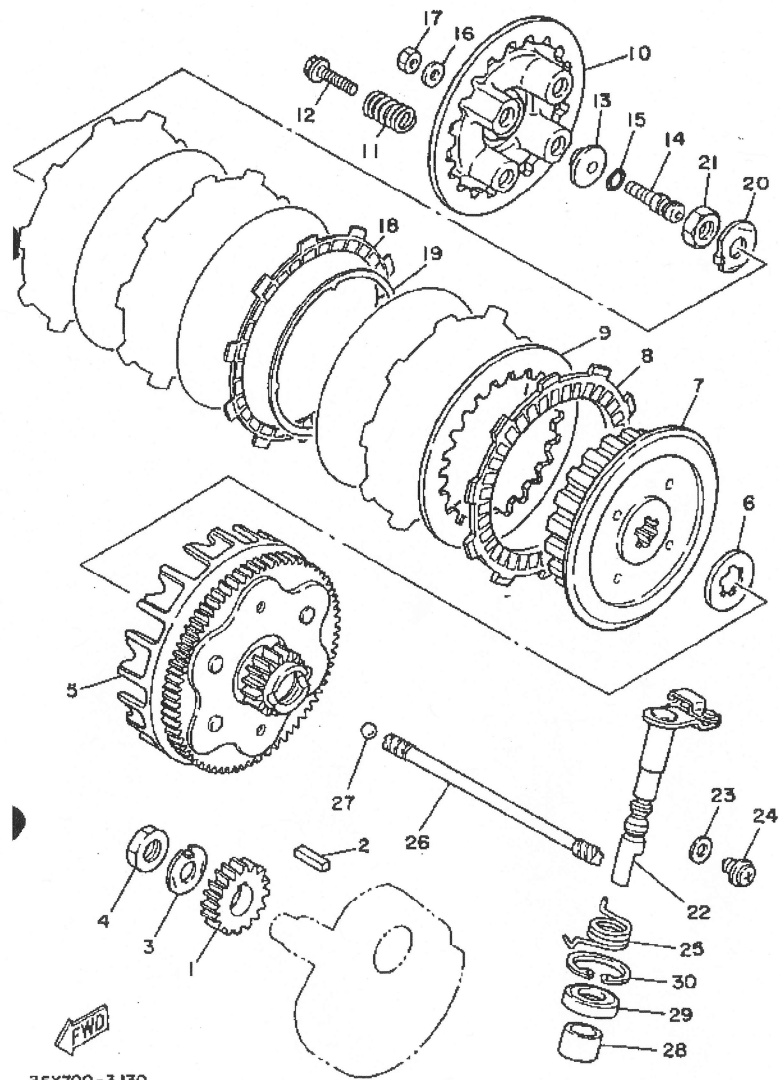

FIG. 13 CLUTCH

REF. NO.	PART NO.	DESCRIPTION	Q'TY	REMARKS
1	36X-16111-00	GEAR, primary drive	1	
2	90282-05043	KEY, straight	1	
3	90215-14205	WASHER, lock	1	
4	90170-14284	NUT	1	
5	36X-16150-00	PRIMARY DRIVEN GEAR COMP.	1	
6	5H0-16154-00	PLATE, thrust 1	1	
7	36X-16371-00	BOSS, clutch	1	
8	537-16321-00	PLATE, friction	4	
9	137-16324-00	PLATE, clutch 1	4	
10	5H0-16351-00	PLATE, pressure 1	1	
11	90501-23700	SPRING, compression	4	
12	90159-05011	SCREW, with washer	4	
13	30X-16358-00	PLATE, push	1	
14	5H0-16356-01	ROD, push 1	1	
15	93210-48364	O-RING	1	
16	92901-06200	WASHER, plain	1	
17	95303-06600	NUT	1	
18	36X-16321-00	PLATE, friction	1	
19	36X-16383-00	SPRING, clutch boss	1	
20	90215-14224	WASHER, lock	1	
21	90170-14284	NUT	1	
22	15A-16380-00	PUSH LEVER ASSY	1	
23	90430-08119	GASKET	1	
24	90149-08067	SCREW	1	
25	90508-18537	SPRING, torsion	1	
26	5H0-16357-00	ROD, push 2	1	
27	93505-16006	BALL	1	
28	90386-14103	BUSH	1	

C3



36X700-3 130

FIG. 13 CLUTCH

REF. NO.	PART NO.	DESCRIPTION	Q'TY	REMARKS
29	93102-14209	OIL SEAL	1	
30	93420-28055	CIRCLIP	1	

C4

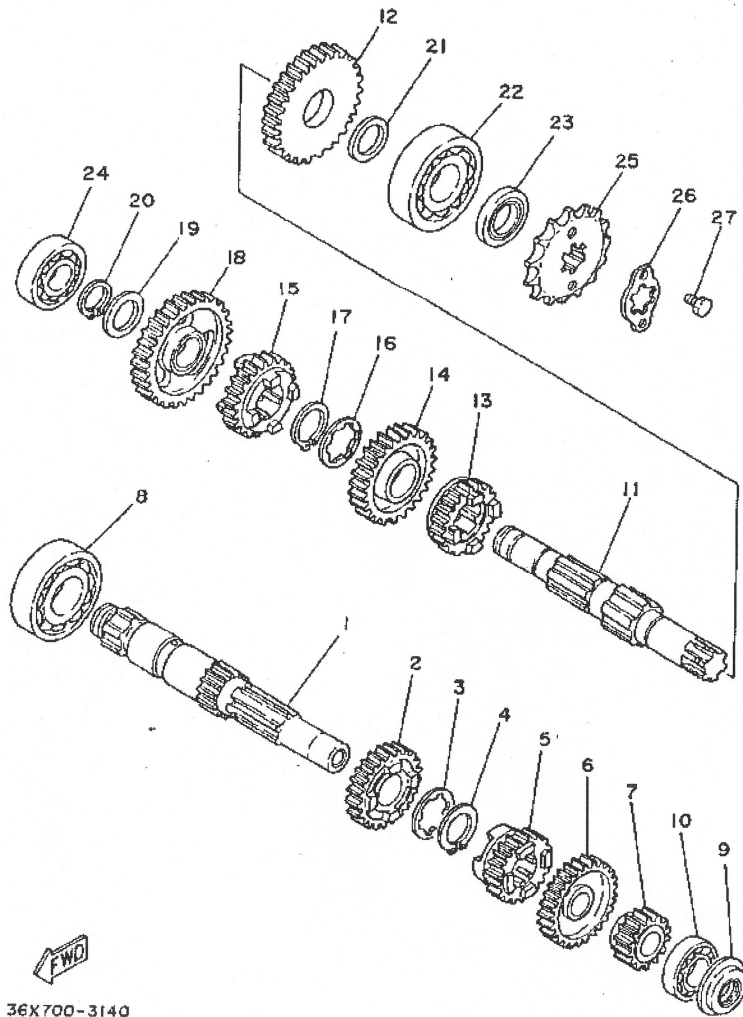

FIG. 14 TRANSMISSION

REF. NO.	PART NO.	DESCRIPTION	Q'TY	REMARKS
1	36X-17411-00	AXLE, main	1	
2	36X-17141-01	GEAR, 4th pinion	1	
3	90209-16209	WASHER	1	
4	93410-20038	CIRCLIP	1	
5	24W-17131-00	GEAR, 3rd pinion (21T)	1	
6	36X-17151-00	GEAR, 5th pinion	1	
7	24W-17121-00	GEAR, 2nd pinion (15T)	1	
8	93306-20401	BEARING (B6204)	1	
9	93101-15101	OIL SEAL	1	
10	93306-20201	BEARING (B6202)	1	
11	15A-17402-01	DRIVE AXLE ASSY	1	
12	36X-17221-00	GEAR, 2nd wheel	1	
13	36X-17251-00	GEAR, 5th wheel	1	
14	24W-17231-00	GEAR, 3rd wheel (30T)	1	
15	36X-17241-01	GEAR, 4th wheel	1	
16	90209-18208	WASHER	1	
17	93410-22039	CIRCLIP	1	
18	36X-17211-00	GEAR, 1st wheel	1	
19	90201-17257	WASHER, plate	1	
20	99009-17400	CIRCLIP	1	
21	90201-203E7	WASHER, plate	1	
22	93306-30424	BEARING (B6304A3)	1	
23	93102-20242	OIL SEAL	1	
24	93306-20332	BEARING	1	
25	93822-14043	SPROCKET, drive 14t (5N01746141)	1	
26	5H0-17456-00	HOLDER, sprocket	1	
27	97021-06010	BOLT	2	

C5

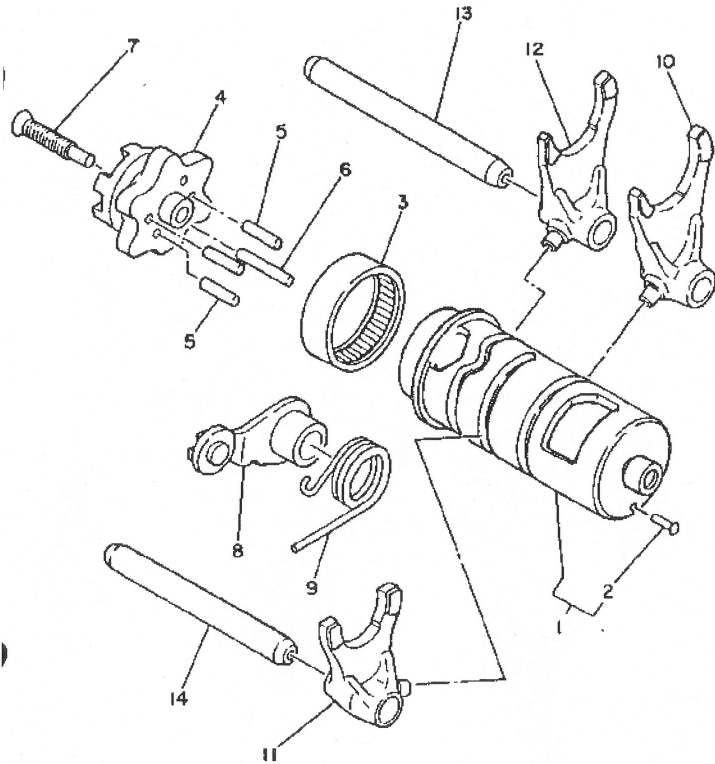

FIG. 15 SHIFT CAM. FORK

REF. NO.	PART NO.	DESCRIPTION	Q'TY	REMARKS
1	36X-18540-00	SHIFT CAM ASSY	1	
2	136-18542-00	.PDINT, neutral	1	
3	93315-23607	BEARING, cylindrical	1	
4	5H0-18185-01	SEGMENT	1	
5	93604-16092	PIN, dowel	4	
6	93604-20156	PIN, dowel	1	
7	90151-06013	SCREW, countersunk	1	
8	4G0-18140-00	STOPPER LEVER ASSY	1	
9	90508-26539	SPRING, torsion	1	
10	36X-18513-00	FORK, shift 3	1	
11	5H0-18511-00	FORK, shift 1	1	
12	5H0-18512-00	FORK, shift 2	1	
13	5H0-18531-00	BAR, shift fork guide 1	1	
14	3Y1-18535-00	BAR, shift fork guide 2	1	



36X700-3150

C6

FIG. 16 SHIFT SHAFT

REF. NO.	PART NO.	DESCRIPTION	Q'TY	REMARKS
1	540-18120-00	SHIFT LEVER ASSY	1	
2	90506-08227	.SPRING, tension	1	
3	90508-29540	SPRING, torsion	1	
4	99001-10600	CIRCLIP	1	
5	90201-12588	WASHER, plate	2	
6	93608-50158	PIN, dowel	1	
7	93102-12106	OIL SEAL (SD 12-22-5 HS)	1	
8	245-18111-00	PEDAL, shift	1	
9	132-18113-01	COVER, shift pedal	1	
10	97011-06020	BOLT	1	

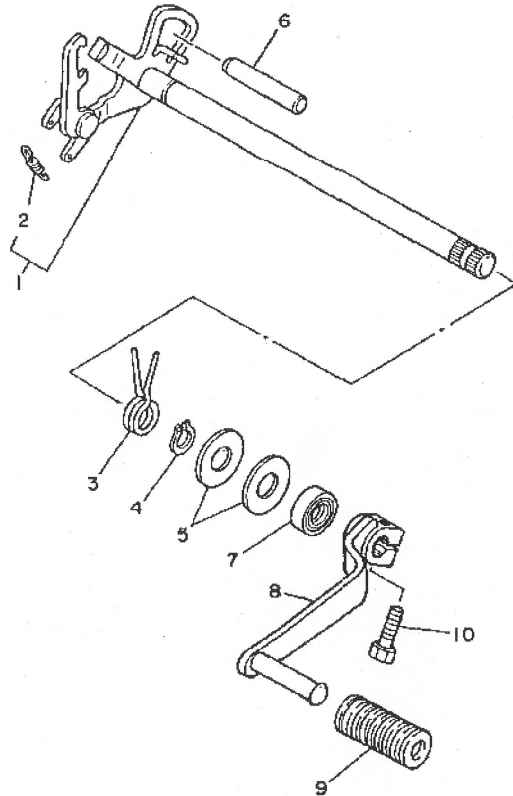

3GX700-8160

C7

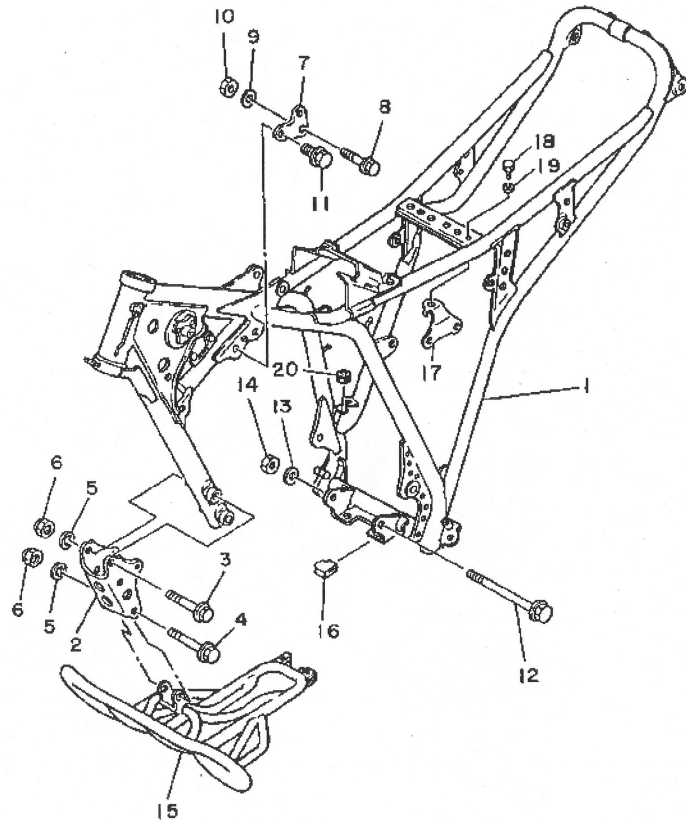

36X700-3171

FIG. 17 FRAME

REF. NO.	PART NO.	DESCRIPTION	Q'TY	REMARKS
1	36X-21110-00-33	FRAME COMP.	1	UR YAMAHA BLACK FOR AUSTRALIA
	36X-21110-00-33	FRAME COMP.	1	UR YAMAHA BLACK FOR OTHER COUNTRIES
2	36X-21316-00	STAY, engine 3	1	
3	95811-08065	BOLT, flange	3	
4	95811-08070	BOLT, flange	1	
5	90201-09461	WASHER, plate	4	
6	90185-08089	NUT, self-locking	4	
7	36X-21315-00	STAY, engine 2	1	
8	95812-08050	BOLT, flange	1	
9	90201-09461	WASHER, plate	1	
10	90185-08089	NUT, self-locking	1	
11	90105-08155	BOLT, washer based	2	
12	95811-08120	BOLT, flange	1	
13	90201-09461	WASHER, plate	1	
14	90185-08089	NUT, self-locking	1	
15	36X-21471-00	PROTECTOR, engine	1	
16	36X-21485-00	DAMPER, rubber 1	2	
17	36X-21287-00	BRACKET, regulator	1	
18	97001-06012	BOLT	1	
19	92990-06100	WASHER, spring	1	
20	90480-14229	GROMMET	1	

C8

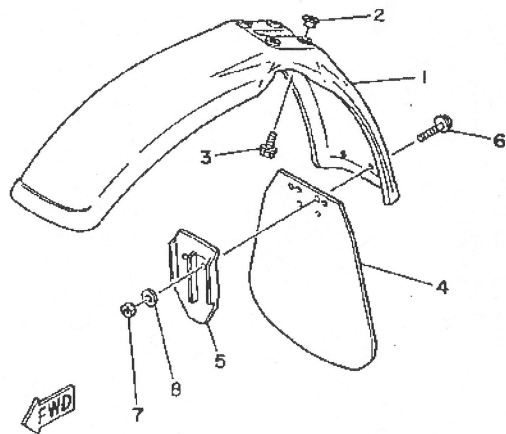
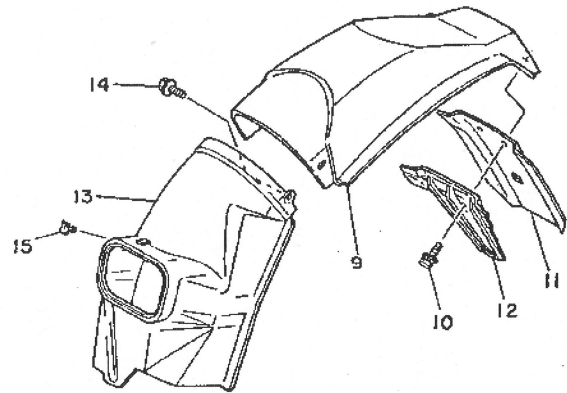

36X700-3180

FIG. 18 FENDER

REF. NO.	PART NO.	DESCRIPTION	Q'TY	REMARKS
1	36X-21511-01	FENDER, front	1	UR COMPETITIONA YELLOW
	36X-21511-10	FENDER, front	1	UR BEIGE
2	90387-06681	COLLAR	4	
3	90119-06063	BOLT, with washer	4	
4	36X-21521-00	FLAP, front fender	1	
5	36X-21522-00	BAND, flap	1	
6	90159-06085	SCREW, with washer	2	
7	95303-06700	NUT	2	
8	90201-065F3	WASHER, plate	2	
9	36X-21611-00	FENDER, rear	1	UR COMPETITION YELLOW
	36X-21611-10	FENDER, rear	1	UR BEIGE
10	90119-06097	BOLT, with washer	2	
11	36X-21621-00	FLAP	1	
12	36X-21622-00	BAND, flap	1	
13	36X-21629-00	GUARD, mud	1	
14	90119-06063	BOLT, with washer	2	
15	90464-16021	CLAMP	1	

C9

FIG. 19 SIDE COVER

REF. NO.	PART NO.	DESCRIPTION	Q'TY	REMARKS
1	36X-21711-00	COVER, side 1	1	UR COMPETITION YELLOW
	36X-21711-10	COVER, side 1	1	UR BEIGE
2	36X-21721-00	COVER, side 2	1	UR COMPETITION YELLOW
	36X-21721-10	COVER, side 2	1	UR BEIGE
3	90480-12320	GROMMET	3	
4	3N7-21746-00	DAMPER	5	
5	90480-01141	GROMMET	1	
6	36X-2172A-00	PANEL 1	1	
7	92501-06012	SCREW, pan head	2	
8	92990-06600	WASHER, plate	2	
9	36X-21781-00	EMBLEM 1	2	UR FOR CPY
	36X-21781-10	EMBLEM 1	2	UR FOR CRI
10	36X-2177F-00	COVER	1	

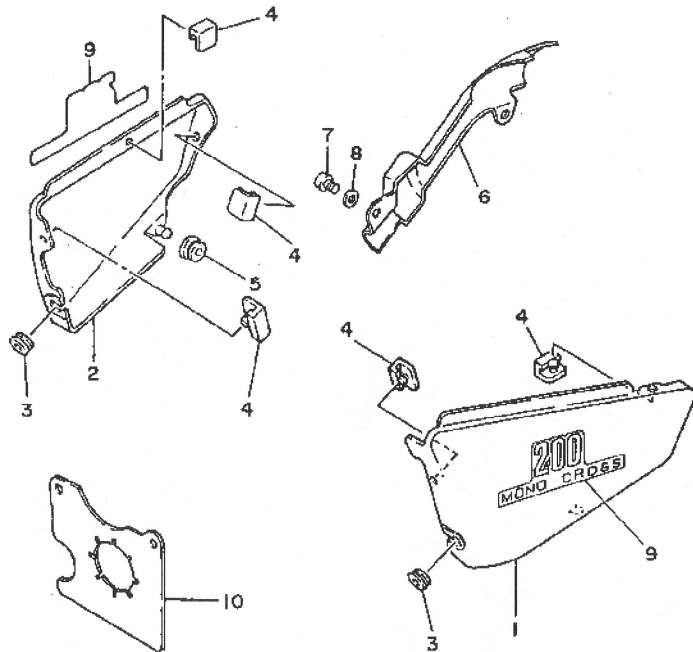

36X700-3191

C10

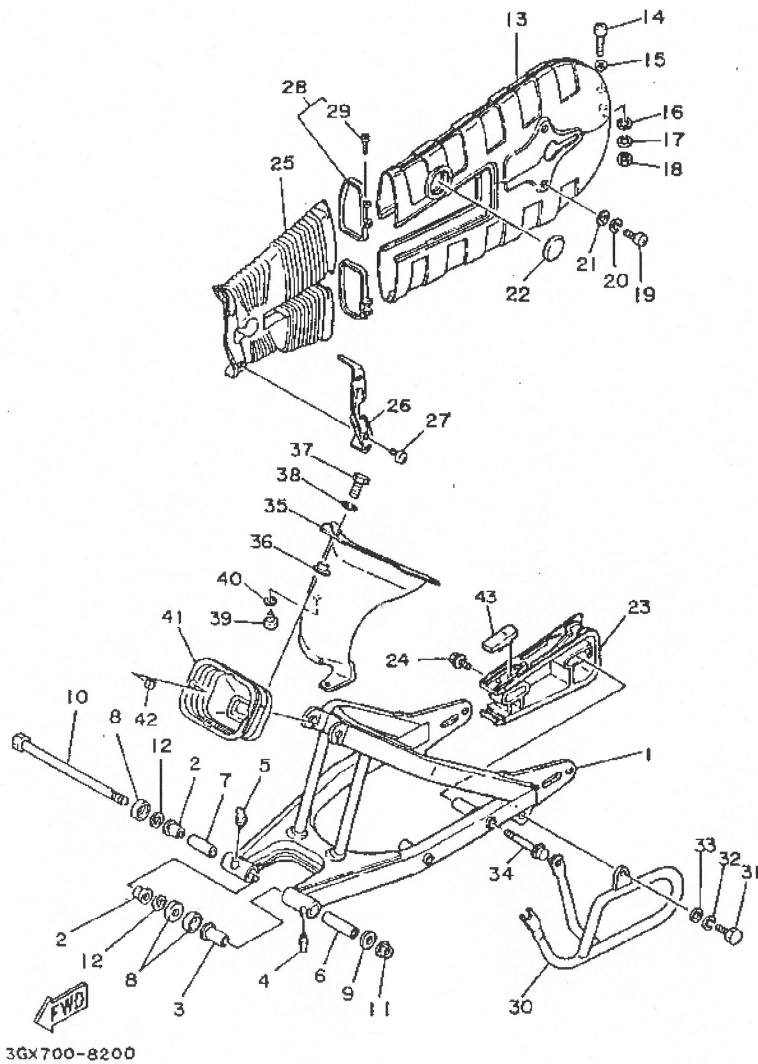

FIG. 20 REAR ARM

REF. NO.	PART NO.	DESCRIPTION	Q'TY	REMARKS
1	36X-22110-00-35	REAR ARM COMP.	1	SILVER
2	15A-22123-00	BUSH 1	2	
3	90386-18028	BUSH	1	
4	93700-06004	NIPPLE, grease	1	
5	93700-06009	NIPPLE, grease	1	
6	36X-22126-00	COLLAR, distance	1	
7	36X-22126-10	COLLAR, distance	1	
8	401-22128-01	SEAL, guard	3	
9	93109-18020	OIL SEAL	1	
10	36X-22141-00	SHAFT, pivot	1	
11	90185-12072	NUT, self-locking	1	
12	401-22127-00	SHIM	1	
13	36X-22310-00-35	CHAIN CASE ASSY	1	SILVER
14	92503-06045	SCREW, pan head	1	
15	92901-06600	WASHER, plate	1	
16	92901-06200	WASHER, plain	1	
17	92990-06100	WASHER, spring	1	
18	95303-06600	NUT	1	
19	92501-06014	SCREW, pan head	2	
20	92990-06100	WASHER, spring	2	
21	92901-06600	WASHER, plate	2	
22	148-22315-00	CAP	1	
23	36X-22358-00	SEAL 1	1	
24	90119-06074	BOLT, with washer	1	
25	36X-22325-00	COVER, dust	1	
26	36X-22324-00	STAY, dust cover	1	
27	98501-05008	SCREW, pan head	2	
28	36X-22323-00	STAY, chain case 3	2	

C11

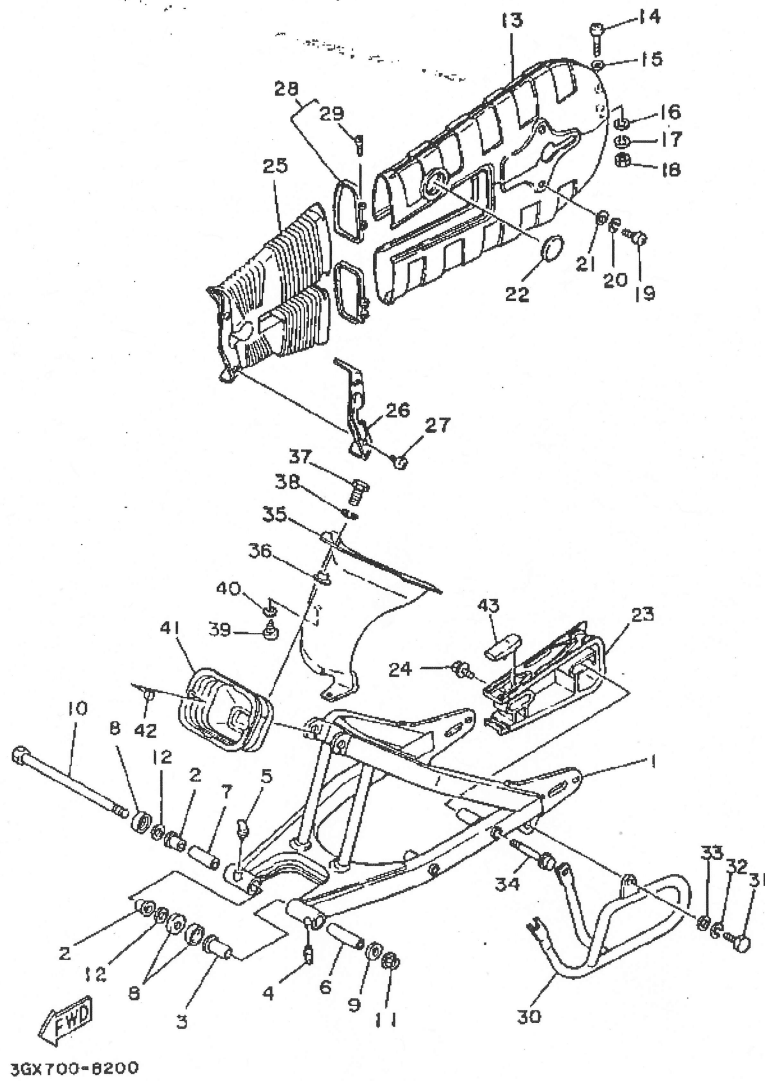
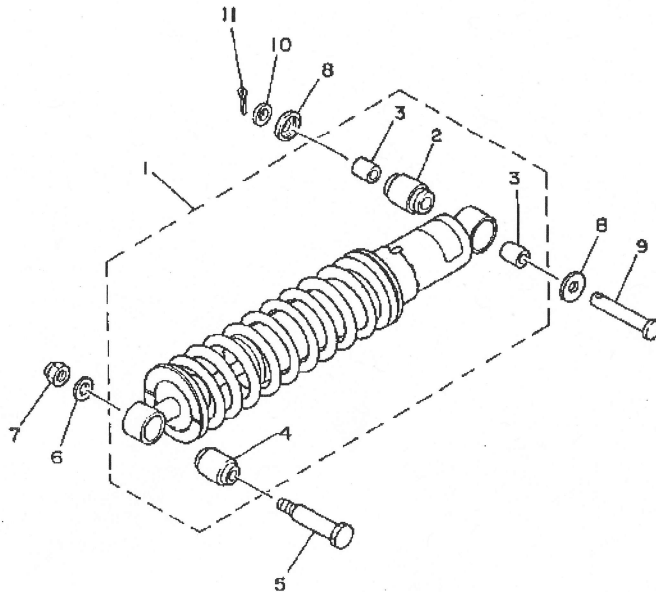

FIG. 20 REAR ARM

REF. NO.	PART NO.	DESCRIPTION	Q'TY	REMARKS
29	98506-04030	.SCREW, pan head	1	
30	36X-22318-00	GUARD, chain	1	
31	97313-08012	BOLT	2	
32	92990-08100	WASHER, spring	2	
33	92901-08500	WASHER, plate	2	
34	95811-08090	BOLT, flange	1	
35	36X-22327-00	MUD GUARD 1	1	
36	90387-06681	COLLAR	1	
37	97002-06016	BOLT	1	
38	92990-06100	WASHER, spring	1	
39	97780-50512	SCREW, tapping	2	
40	90201-05032	WASHER, plate	2	
41	36X-22189-00	BOOT, rubber	1	
42	90468-06134	CLIP	4	
43	36X-22151-00	SEAL, guard	1	

FIG. 21 REAR SUSPENSION

REF. NO.	PART NO.	DESCRIPTION	Q'TY	REMARKS
1	36X-22210-00	SHOCK ABSORBER ASSY, rear	1	
2	3R4-22226-00	.BUSH, shock absorber lower	1	
3	90380-12051	.BUSH, solid	2	
4	1YW-22216-00	.BUSH, rear shock absorber	1	
5	90109-10554	BOLT	1	
6	90201-10269	WASHER, plate	1	
7	95602-10100	NUT, u	1	
8	1W1-22128-00	COVER, thrust 1	2	
9	90240-12092	PIN, clevis	1	
10	92990-12600	WASHER, plate	1	
11	91401-30025	PIN, cotter	1	



36X700-3210

C13

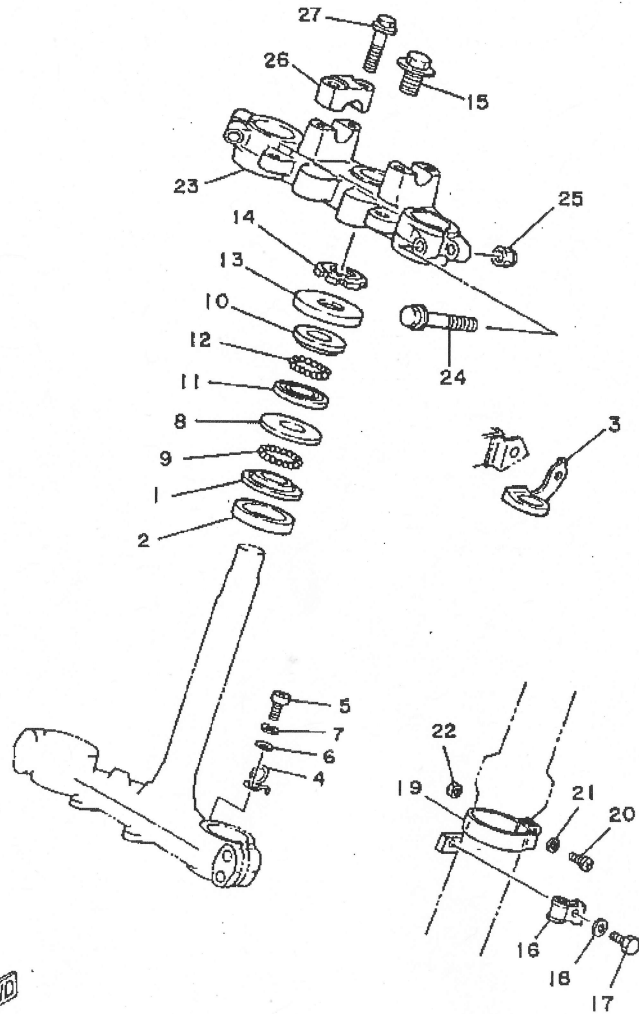

FIG. 22 STEERING

REF. NO.	PART NO.	DESCRIPTION	Q'TY	REMARKS
1	156-23411-00	RACE, ball 1	1	
2	164-23462-00	SEAL, steering	1	
3	36X-23389-00	GUIDE, cable	1	
4	36X-2331E-00	GUIDE, cable	1	
5	92506-06012	SCREW, pan head	1	
6	92906-06600	WASHER, plate	1	
7	92906-06100	WASHER, spring	1	
8	156-23412-00	RACE, ball 2	1	
9	93501-04011	BALL	19	
10	122-23411-00	RACE, ball 1	1	
11	122-23412-00	RACE, ball 2	1	
12	93503-16010	BALL	22	
13	36X-23416-00	COVER, ball race 2	1	
14	90179-25033	NUT	1	
15	90105-14102	BOLT, washer based	1	
16	3Y1-23319-00	HOLDER, cable 2	1	
17	97006-06012	BOLT	1	
18	92906-06100	WASHER, spring	1	
19	3R9-23318-00	HOLDER, cable 1	1	
20	98501-05016	SCREW, pan head	1	
21	92901-05600	WASHER, plate	1	
22	95303-05600	NUT	1	
23	36X-23435-00	CROWN, handle	1	
24	95826-10060	BOLT, flange	2	
25	90185-10091	NUT, self-locking	2	
26	1E6-23441-00	HOLDER, handle upper	2	
27	95816-08035	BOLT, flange	4	



36X700-8220

C14

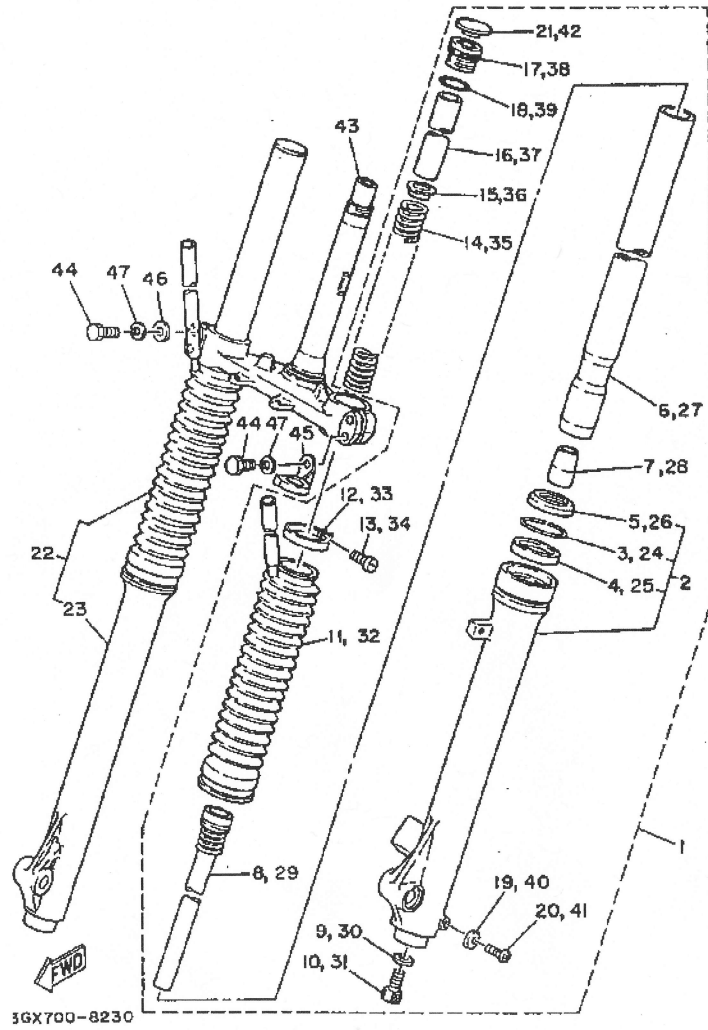

FIG. 23 FRONT FORK

REF. NO.	PART NO.	DESCRIPTION	Q'TY	REMARKS
29	36X-23170-00	.CYLINDER COMP., front fork	1	
30	509-23158-L0	.GASKET	1	
31	278-23181-50	.BOLT, hexagon socket head	1	
32	36X-23191-01	.BOOT	1	
33	36X-23192-00	.BAND	1	
34	4V2-23194-L0	.SCREW, boot band	1	
35	36X-23141-00	.SPRING, front fork	1	
36	583-23142-00	.SEAT, spring upper	1	
37	36X-23118-00	.SPACER	1	
38	11H-23111-00	.BOLT, cap	1	
39	240-23114-00	.GASKET	1	
40	122-23129-00	.GASKET, drain plug	1	
41	4H7-23119-00	.PLUG, drain	1	
42	1U6-23168-M1	.CAP, front fork	1	
43	36X-23340-00-33	UNDER BRACKET COMP.	1	YAMAHA BLACK
44	36X-23128-00	BOLT, axle holder	4	
45	5Y1-23389-00	GUIDE, cable	1	
46	36X-23392-00	WASHER, special	2	
47	92906-08100	WASHER, spring	4	

D2

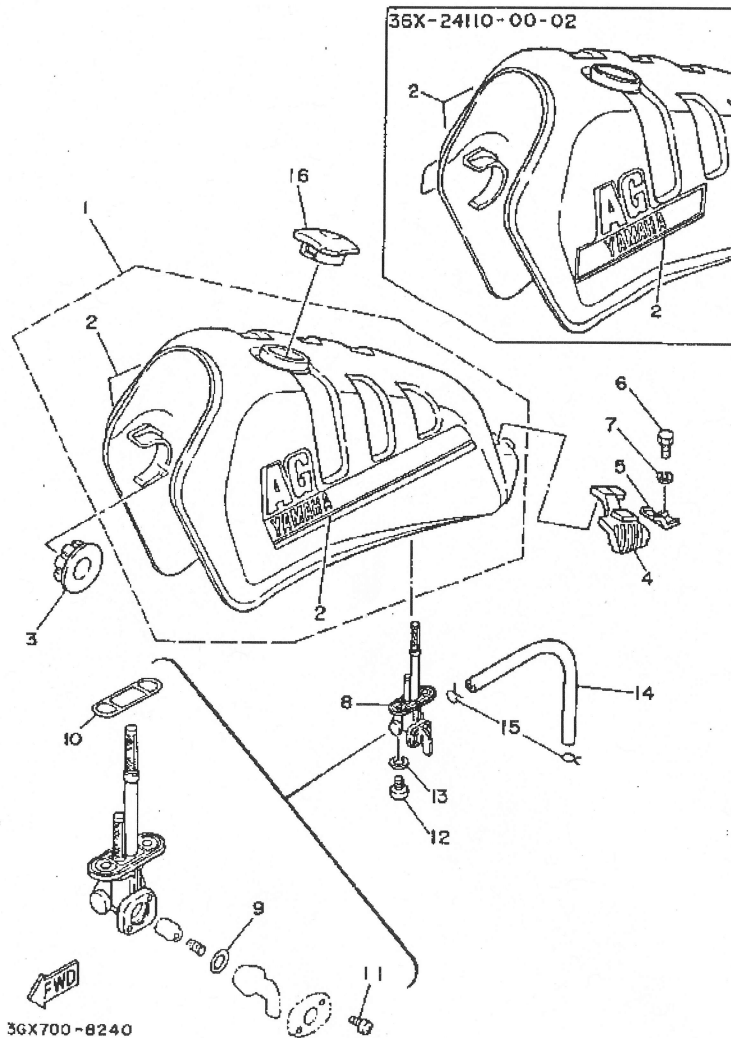
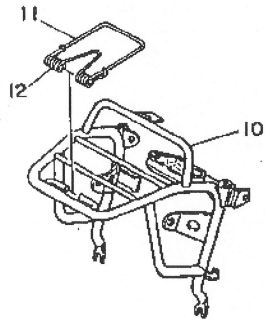
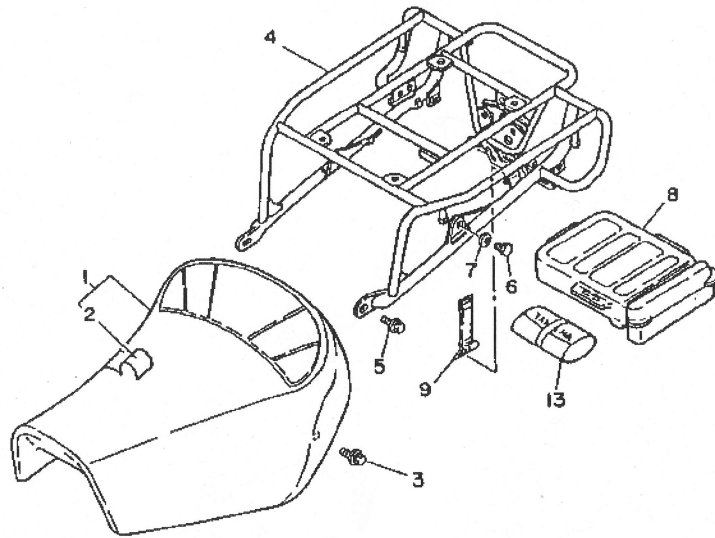

FIG. 24 FUEL TANK

REF. NO.	PART NO.	DESCRIPTION	Q'TY	REMARKS
1	36X-24110-00-01	FUEL TANK COMP.	1	UR COMPETITION YELLOW
	36X-24110-00-02	FUEL TANK COMP.	1	UR CERAMIC IVORY
2	36X-24240-00	.GRAPHIC SET	1	UR FOR CPY
	36X-24244-00	.GRAPHIC, fuel tank 1	2	UR FOR CRI
3	4H7-24181-00	DAMPER, locating 1	2	
4	36X-24182-00	DAMPER, locating 2	1	
5	36X-24186-00	WASHER, special	2	
6	97002-06016	BOLT	2	
7	92990-06100	WASHER, spring	2	
8	15A-24500-02	FUEL COCK ASSY 1	1	
9	4XB-24534-00	.SEAL, cock	1	
10	4XB-24572-00	.GASKET	1	
11	97801-03008	.SCREW, pan head	2	
12	90149-06011	SCREW	2	
13	90202-06010	WASHER, plate	2	
14	90445-10638	HOSE	1	
15	90467-09006	CLIP	2	
16	36X-24610-00	CAP ASSY	1	

D3



36X700-3250

FIG. 25 SEAT

REF. NO.	PART NO.	DESCRIPTION	Q'TY	REMARKS
1	36X-24710-00	SINGLE SEAT ASSY	1	UR BLACK FOR CPY
	36X-24710-00	SINGLE SEAT ASSY	1	UR RED FOR CRI
2	36X-24711-00	.COVER, single seat	1	UR BLACK
	36X-24711-00	.COVER, single seat	1	UR RED
3	90119-06061	BOLT, with washer	2	
4	36X-24810-00	CARRIER ASSY	1	
5	95816-08012	BOLT, flange	2	
6	90105-08141	BOLT, washer based	1	
7	90201-081H4	WASHER, plate	1	
8	36X-21107-00	TOOL BOX COMP.	1	
9	36X-2811G-00	BAND	1	
10	36X-24860-00-98	FRONT CARRIER ASSY	1	LOW GLOSS BLACK
11	36X-24862-00	CLAMP, carrier	1	
12	36X-24861-00	SPRING, front carrier	1	
13	36X-W2810-00	TOOL KIT	1	

D4

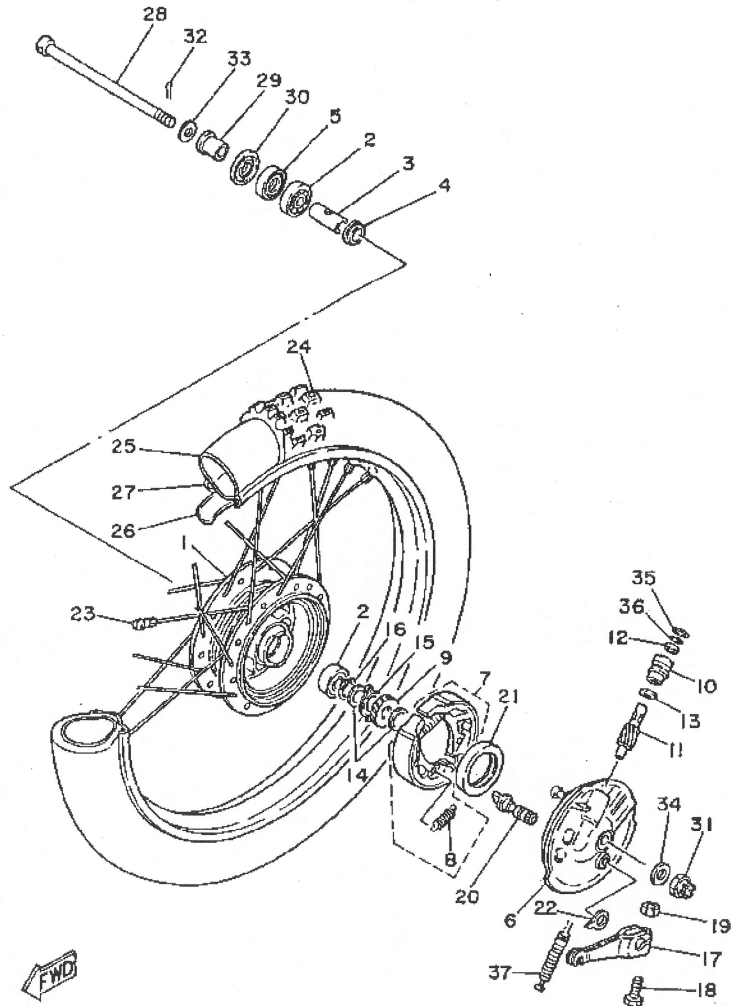

FWD
3GX700-8260

FIG. 26 FRONT WHEEL

REF. NO.	PART NO.	DESCRIPTION	Q'TY	REMARKS
1	248-25111-00-Y8	HUB, front	1	SILVER
2	93306-30109	BEARING	2	
3	90560-12138	SPACER	1	
4	109-25315-00	FLANGE, spacer	1	
5	93102-18008	OIL SEAL	1	
6	23F-25121-00-35	PLATE, brake shoe	1	SILVER
7	22F-W2534-00	BRAKE SHOE KIT 2	1	
8	90506-18288	.SPRING, tension	2	
9	36X-25135-00	GEAR, drive	1	
10	109-25136-00	BUSH	1	
11	36X-25138-00	GEAR, meter	1	
12	93104-07003	OIL SEAL	1	
13	90201-07076	WASHER, plate	1	
14	90201-20269	WASHER, plate	2	
15	183-25149-00	CLUTCH, meter	1	
16	99009-20400	CIRCLIP	1	
17	5H0-25155-00	LEVER, camshaft 1	1	
18	90101-06278	BOLT	1	
19	95303-06600	NUT	1	
20	3Y6-25351-00	CAMSHAFT	1	
21	93105-47007	OIL SEAL	1	
22	23F-2533A-00	PLATE, indicator	1	
23	3Y6-25104-00	SPOKE SET, front	1	
24	94130-195E9	TIRE (3.00-19)	1	
25	94227-19177	TUBE (2.75-19)	1	DUNLOP
26	94327-19111	BAND, rim (2.75-19)	1	INDUE
27	94416-19263	RIM (1.60-19)	1	
28	353-25381-00	AXLE, wheel	1	

D5

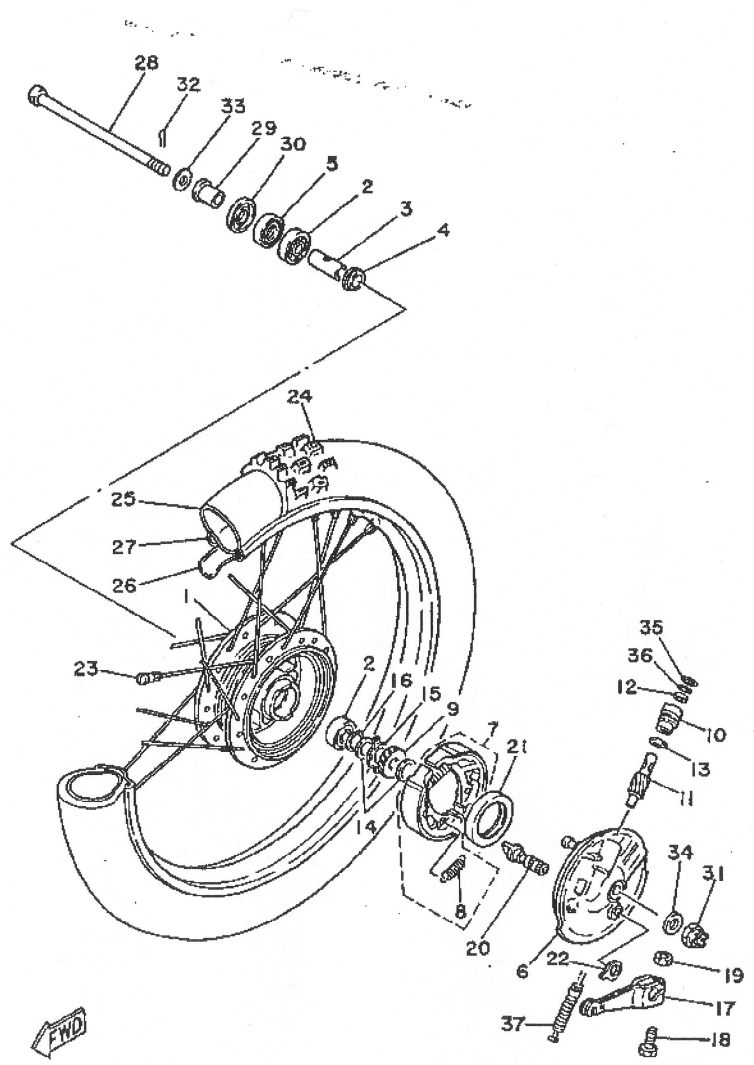

FWD
36X700-8260

FIG. 26 FRONT WHEEL.

REF. NO.	PART NO.	DESCRIPTION	Q'TY	REMARKS
29	90387-12265	COLLAR	1	
30	2K5-25118-00	COVER, hub dust	1	
31	90171-10004	NUT, castle	1	
32	91401-20020	PIN, cotter	1	
33	90201-122A7	WASHER, plate	1	
34	92901-10200	WASHER, plain	1	
35	102-25137-00	RING, stop	1	
36	93210-14104	O-RING	1	
37	90501-12792	SPRING, compression	1	

D6

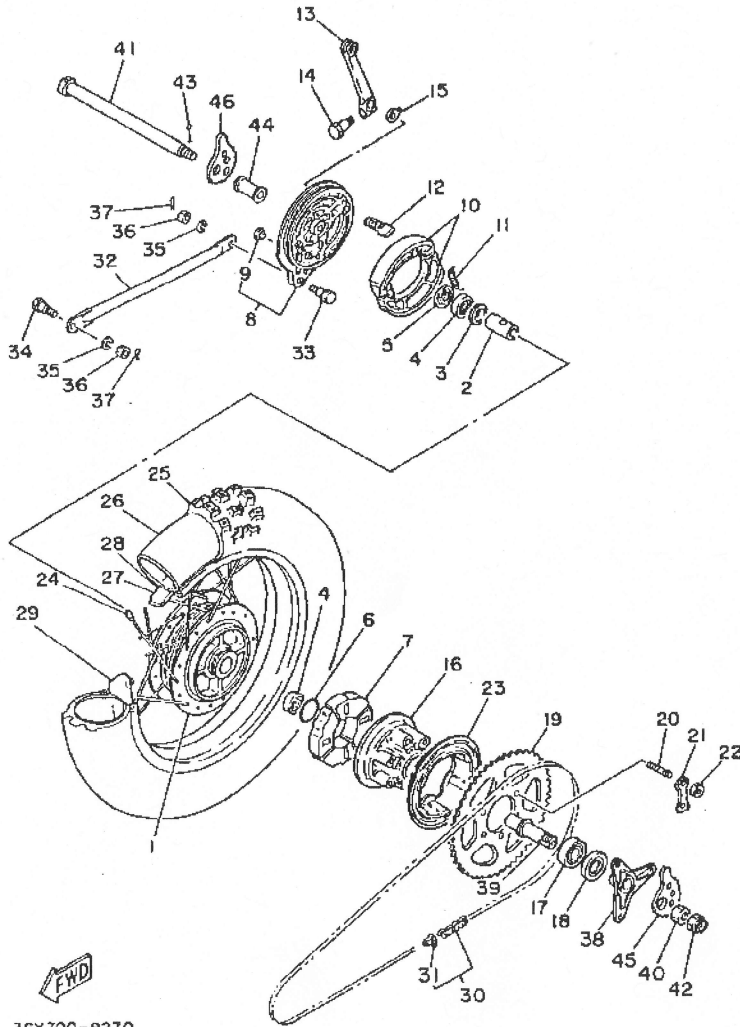

FIG. 27 REAR WHEEL

REF. NO.	PART NO.	DESCRIPTION	Q'TY	REMARKS
1	391-25311-00-38	HUB, rear	1	CLEAR (WITH BUFF)
2	90560-15136	SPACER	1	
3	146-25116-00	FLANGE, spacer 2	1	
4	93306-20204	BEARING (86202Z)	2	
5	93104-22018	OIL SEAL	1	
6	93210-42101	O-RING	1	
7	36X-25364-00	DAMPER	4	
8	437-25026-10-35	BRAKE SHOE PLATE ASSY	1	SILVER
9	90480-10068	GROMMET	1	
10	437-W2536-00	BRAKE SHOE SET	1	
11	90506-16036	SPRING, tension	2	
12	2RH-25351-00	CAMSHAFT	1	
13	4V8-25355-00	LEVER, camshaft	1	
14	90101-06291	BOLT	1	
15	5T9-2533A-00	PLATE, indicator	1	
16	31G-25366-00	CLUTCH, hub	1	
17	93306-00406	BEARING (86004Z)	1	
18	93106-26005	OIL SEAL	1	
19	15A-25454-10-33	SPROCKET, driven (54T)	1	YAMAHA BLACK
20	90116-08425	BOLT, stud	6	
21	90215-08160	WASHER, lock	3	
22	90170-08258	NUT	6	
23	36X-25327-00	COVER, plate	1	
24	3V6-25304-00	SPOKE SET, rear	1	
25	94141-185E8	TIRE (4.10-18)	1	
26	94235-18085	TUBE (3.50-18)	1	YOKOHAMA
27	94325-18043	BAND, rim (2.50-18)	1	INOUE
28	94418-18246	RIM (1.85-18)	1	

D7

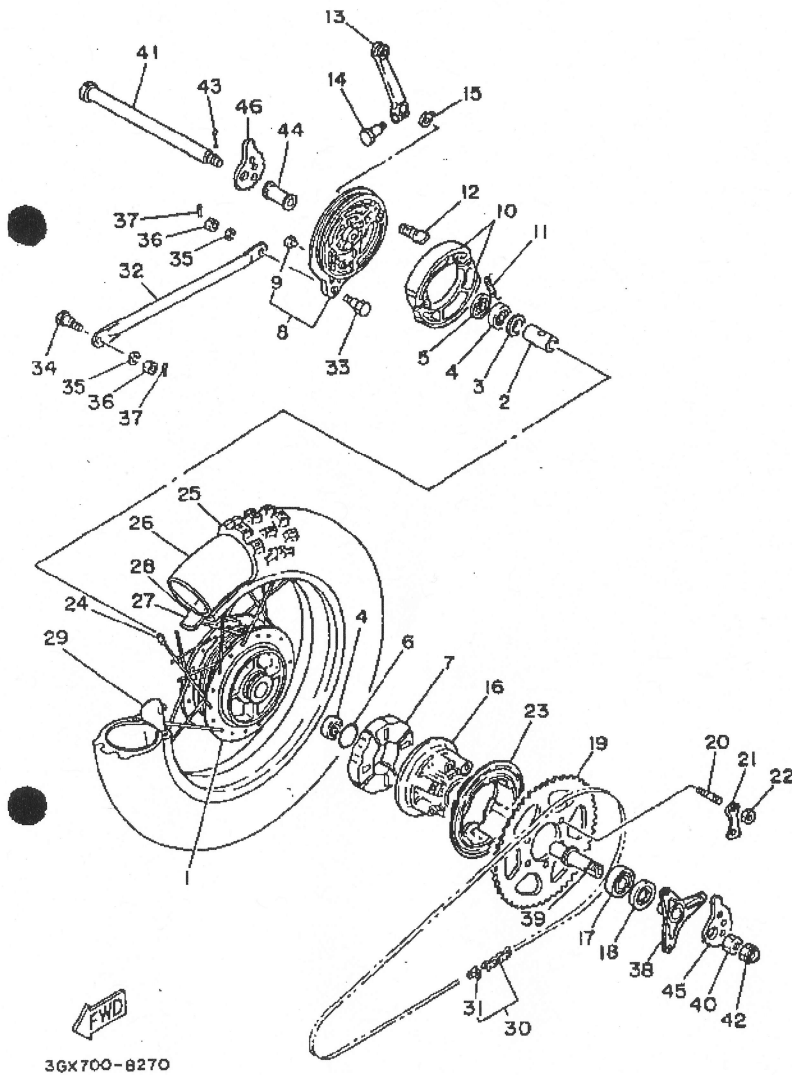
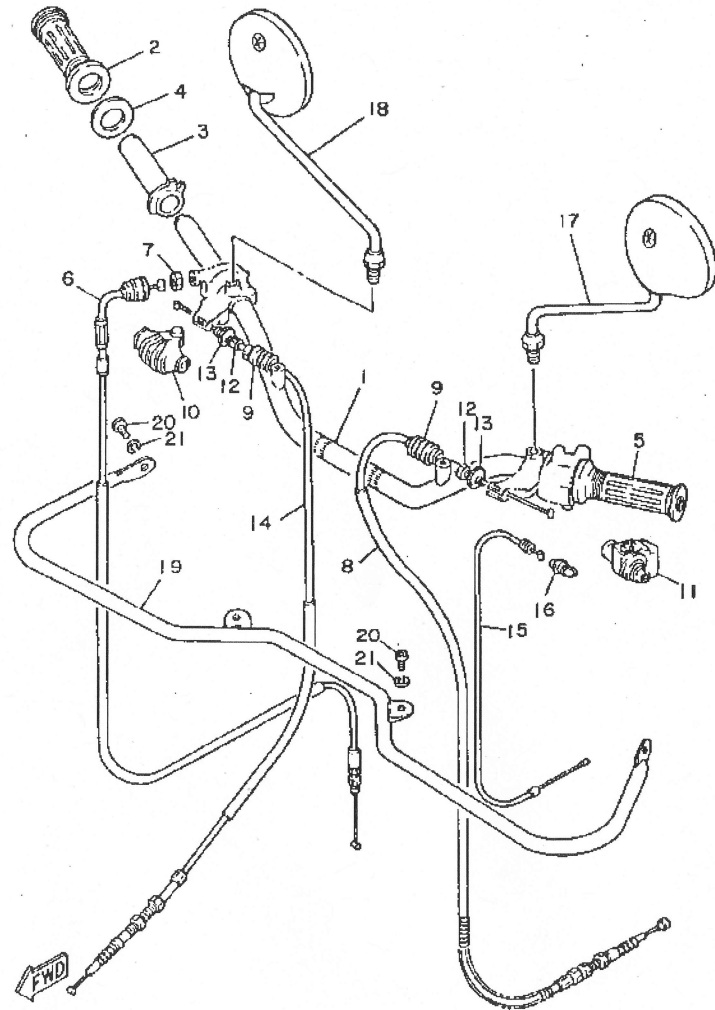

FIG. 27 REAR WHEEL

REF. NO.	PART NO.	DESCRIPTION	Q'TY	REMARKS
29	1T2-25394-00	SPACER, bead	1	
30	94580-33126	CHAIN (D.I.D.428DS-126L)	1	
31	94680-33001	JOINT, chain (D.I.D.428DS)	1	
32	3V6-25371-00	BAR, tension	1	
33	90109-08063	BOLT	1	
34	90109-08368	BOLT	1	
35	92990-08100	WASHER, spring	2	
36	95303-08700	NUT	2	
37	91401-20015	PIN, cotter	2	
38	36X-25386-00	COLLAR, sprocket axle	1	
39	36X-25387-00	AXLE, sprocket	1	
40	90170-20167	NUT	1	
41	2X6-25381-00	AXLE, wheel	1	
42	90171-14020	NUT, castle	1	
43	91401-30030	PIN, cotter	1	
44	90387-155J5	COLLAR	1	
45	3V6-25388-00	PULLER, chain 1	1	
46	3V6-25389-00	PULLER, chain 2	1	

D8



3GX700-8280

FIG. 28 STEERING HANDLE. CABLE

REF. NO.	PART NO.	DESCRIPTION	Q'TY	REMARKS
1	36X-26111-00	HANDLEBAR	1	YAMAHA BLACK
2	2N3-26242-00	GRIP (R.H)	1	BLACK
3	434-26243-00	TUBE, throttle guide	1	
4	1M1-26249-01	RING, leaf	1	
5	2N3-26241-00	GRIP (L.H)	1	BLACK
6	36X-26311-00	CABLE, throttle 1	1	
7	90170-10038	NUT	1	
8	1RH-26335-00	CABLE, clutch	1	
9	1E6-26342-00	BOOT, cable	2	
10	1E6-26372-00	COVER, handle lever 1	1	
11	36X-26372-00	COVER, handle lever 1	1	
12	90123-08046	BOLT	2	
13	90179-08148	NUT	2	
14	36X-26341-00	CABLE, brake	1	
15	36X-26331-00	CABLE, starter 1	1	
16	5Y1-26339-00	BOOT	1	
17	5Y4-26290-30	BACK MIRROR ASSY (L.H)	1	
18	1Y1-26290-40	BACK MIRROR ASSY (R.H)	1	
19	36X-26123-00	GUARD, lever	1	
20	92016-08016	SCREW	4	
21	92906-08100	WASHER, spring	4	

D9

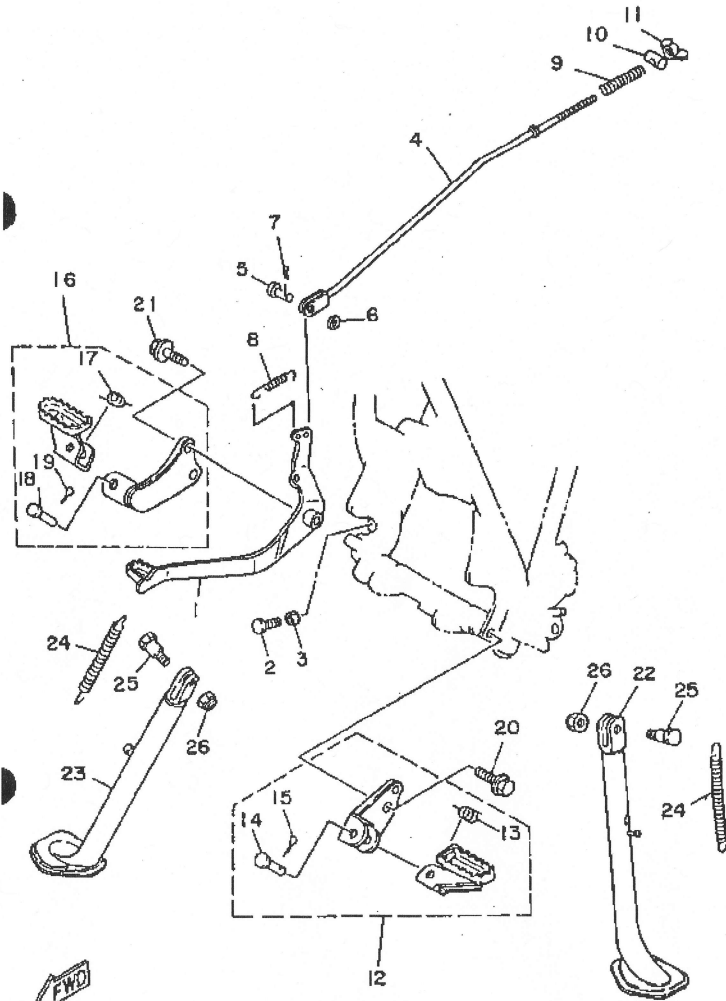

36X700-3290

FIG. 29 STAND. FOOTREST

REF. NO.	PART NO.	DESCRIPTION	Q'TY	REMARKS
1	36X-27211-00-90	PEDAL, brake	1	UNI CHROME (BLACK)
2	97001-06020	BOLT	1	
3	95303-06700	NUT	1	
4	36X-27231-00	ROD, brake	1	
5	90240-06040	PIN, clevis	1	
6	92901-06200	WASHER, plain	1	
7	91401-20015	PIN, cotter	1	
8	90506-14343	SPRING, tension	1	
9	90501-10245	SPRING, compression	1	
10	90249-12008	PIN	1	
11	90175-06013	NUT, wing	1	
12	36X-27410-00-90	FRONT FOOTREST ASSY (LEFT)	1	UNI CHROME (BLACK)
13	90508-20023	.SPRING, torsion	1	
14	91701-08038	.PIN, clevis	1	
15	91401-25015	.PIN, cotter	1	
16	36X-27420-00-90	FRONT FOOTREST ASSY (RIGHT)	1	UNI CHROME (BLACK)
17	90508-20023	.SPRING, torsion	1	
18	91701-08038	.PIN, clevis	1	
19	91401-25015	.PIN, cotter	1	
20	95821-12025	BOLT, flange	1	
21	90105-10058	BOLT, washer based	2	
22	36X-27311-00-33	STAND, side	1	YAMAHA BLACK
23	36X-27311-10-33	STAND, side	1	YAMAHA BLACK
24	90506-26270	SPRING, tension	2	
25	90109-103A1	BOLT	2	
26	90185-10037	NUT, self-locking	2	

D10

FIG. 30 GENERATOR

REF. NO.	PART NO.	DESCRIPTION	Q'TY	REMARKS
1	36X-85550-M0	ROTOR ASSY	1	
2	36X-81410-M0	STATOR ASSY	1	
3	15A-85580-M0	COIL, pulser	1	
4	98501-05030	SCREW, pan head	2	
5	92990-05100	WASHER, spring	2	
6	98503-05025	SCREW, pan head	2	
7	92990-05100	WASHER, spring	2	
8	92501-06020	SCREW, pan head	2	

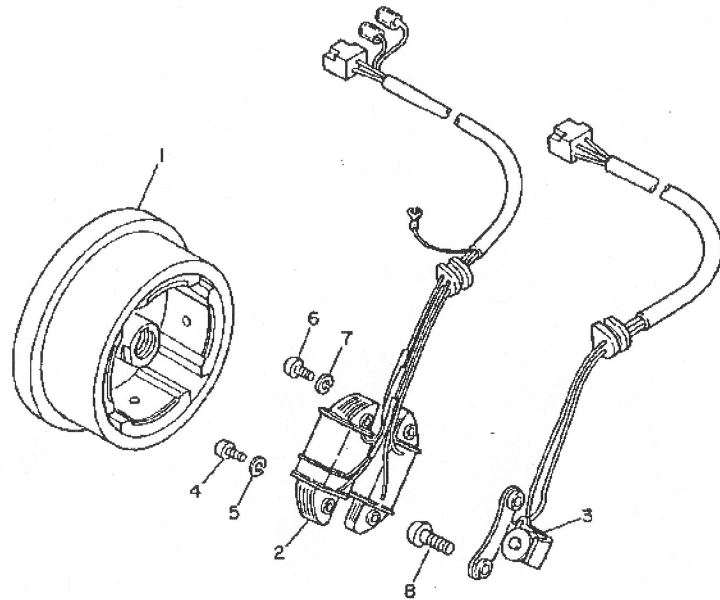

36X700-3301

D11

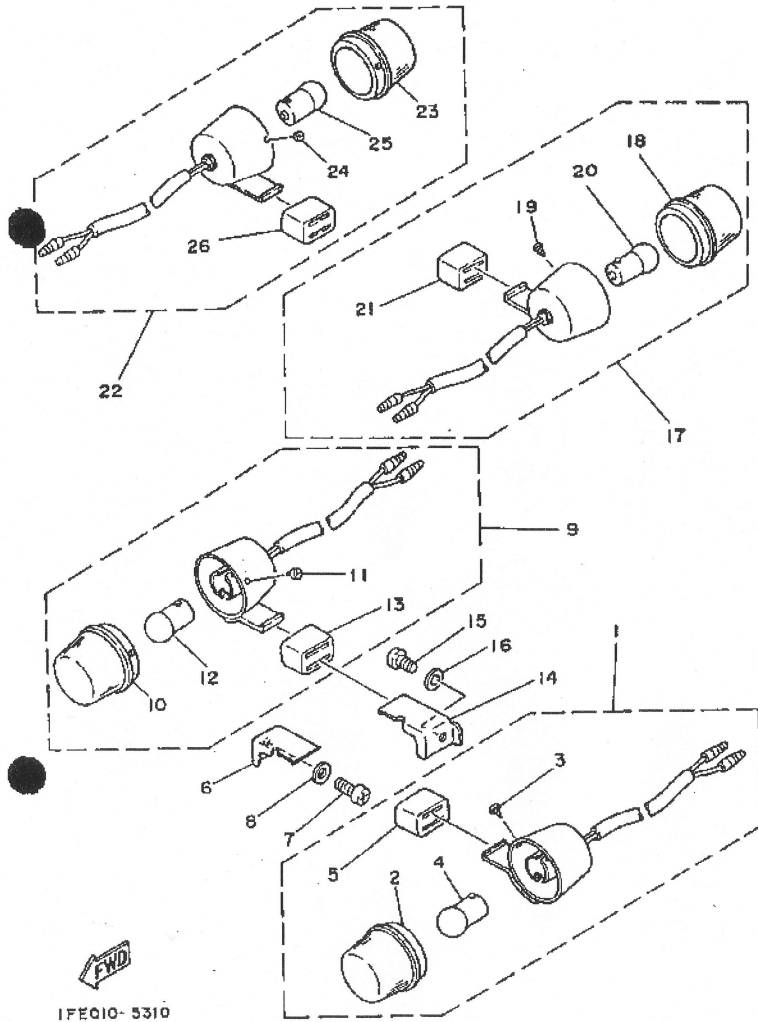

FIG. 31 FLASHER LIGHT

REF. NO.	PART NO.	DESCRIPTION	Q'TY	REMARKS
1	36X-83310-10	FRONT FLASHER LIGHT ASSY 1	1	
2	36X-83312-00	.LENS, flasher	1	
3	97706-30108	.SCREW, tapping	1	
4	185-83311-10	.BULB (6V-8W)	1	
5	36X-83321-00	.DAMPER, flasher 1	1	
6	36X-83318-00	STAY, flasher 1	1	
7	92506-06016	SCREW, pan head	1	
8	92906-06600	WASHER, plate	1	
9	36X-83320-10	FRONT FLASHER LIGHT ASSY 2	1	
10	36X-83312-00	.LENS, flasher	1	
11	97706-30108	.SCREW, tapping	1	
12	185-83311-10	.BULB (6V-8W)	1	
13	36X-83321-00	.DAMPER, flasher 1	1	
14	36X-83328-00	STAY, flasher 2	1	
15	92506-06016	SCREW, pan head	1	
16	92906-06600	WASHER, plate	1	
17	36X-83310-10	FRONT FLASHER LIGHT ASSY 1	1	
18	36X-83312-00	.LENS, flasher	1	
19	97706-30108	.SCREW, tapping	1	
20	185-83311-10	.BULB (6V-8W)	1	
21	36X-83321-00	.DAMPER, flasher 1	1	
22	36X-83310-10	FRONT FLASHER LIGHT ASSY 2	1	
23	36X-83312-00	.LENS, flasher	1	
24	97706-30108	.SCREW, tapping	1	
25	185-83311-10	.BULB (6V-8W)	1	
26	36X-83321-00	.DAMPER, flasher 1	1	

D12

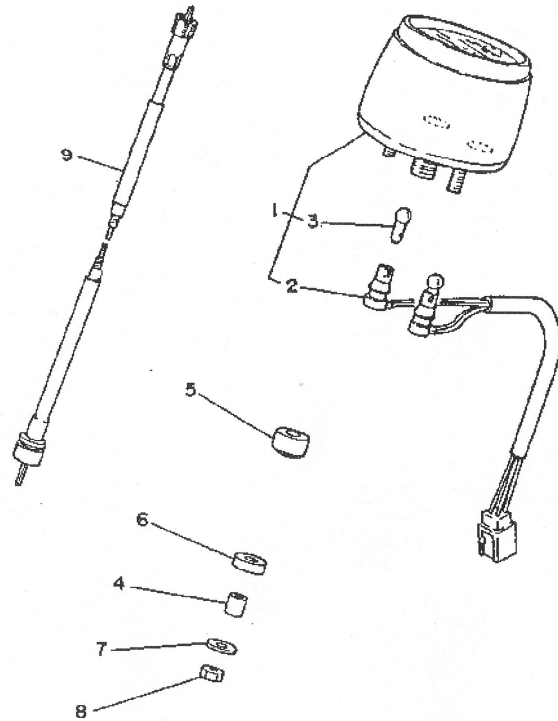

FIG. 32 METER

REF. NO.	PART NO.	DESCRIPTION	Q'TY	REMARKS
1	3F4-83510-F0	SPEEDOMETER ASSY	1	UR KM/H
	3F6-83510-G0	SPEEDOMETER ASSY	1	UR MILE/H
2	4A7-83520-00	.SOCKET CORD ASSY	1	
3	122-83516-10	.BULB (6V-3W)	2	
4	355-83522-00	COLLAR	2	
5	1K3-83513-00	DAMPER	2	
6	355-83526-00	DAMPER 2	2	
7	90201-06412	WASHER, plate	2	
8	95303-06600	NUT	2	
9	1JN-83550-01	SPEEDOMETER CABLE ASSY	1	



3GX700-8320

D13

FIG. 34 TAILLIGHT

REF. NO.	PART NO.	DESCRIPTION	Q'TY	REMARKS
1	36X-84510-00	TAILLIGHT UNIT ASSY	1	
2	1Y1-84521-30	.LENS, taillight	1	
3	98511-03045	.SCREW, pan head	2	
4	122-84514-30	.BULB (6V-17/5.3W)	1	
5	36X-84527-00	DAMPER	1	
6	90387-05563	COLLAR	2	
7	90201-054K4	WASHER, plate	2	
8	97001-05020	BOLT	2	
9	92901-05100	WASHER, spring	2	
10	92901-05600	WASHER, plate	2	

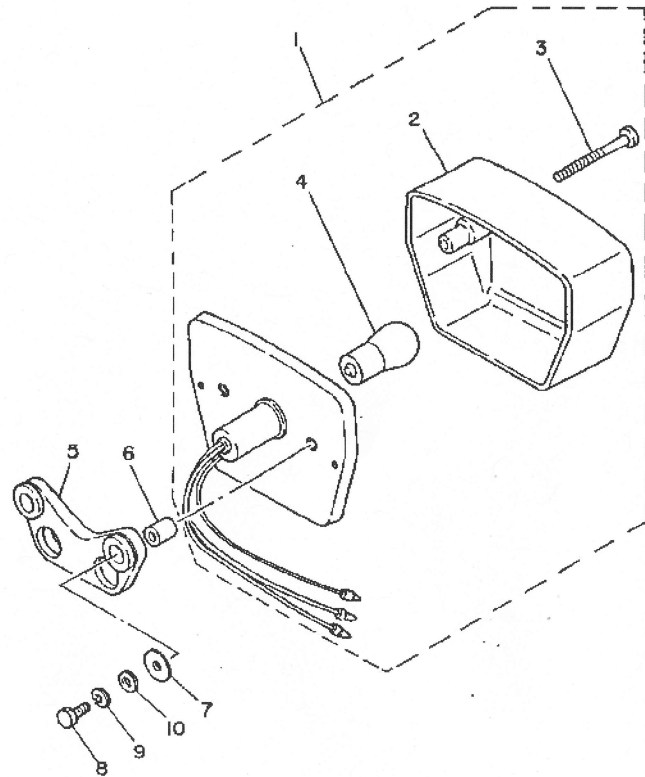

35X700-3340

D15

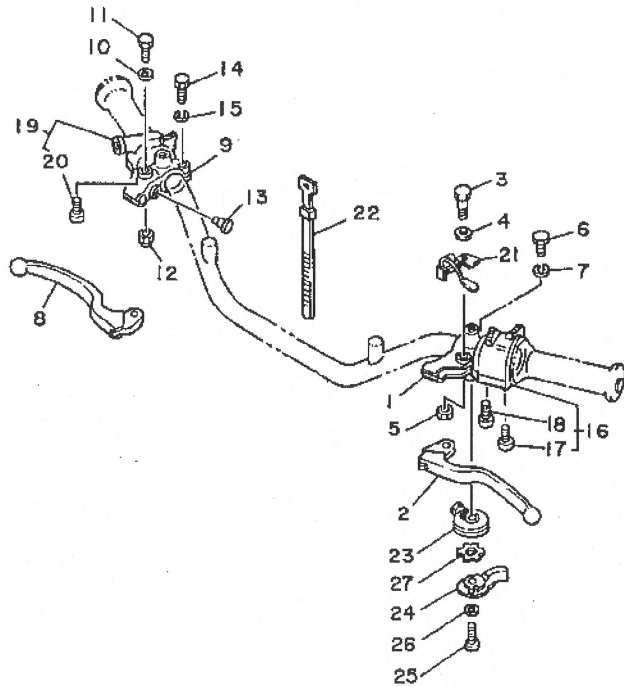

FIG. 35 HANDLE SWITCH. LEVER

REF. NO.	PART NO.	DESCRIPTION	Q'TY	REMARKS
1	5Y1-82911-01	HOLDER, lever 1	1	
2	23X-83912-00	LEVER 1	1	
3	2H7-83945-00	BOLT, lever	1	
4	90201-08083	WASHER, plate	1	
5	95601-06100	NUT, u	1	
6	97006-06022	BOLT	1	
7	92906-06100	WASHER, spring	1	
8	23X-83922-00	LEVER 2	1	
9	361-82921-31	HOLDER, lever 2	1	
10	90201-08083	WASHER, plate	1	
11	90149-05120	SCREW	1	
12	95601-06100	NUT, u	1	
13	503-83956-00	CAP 1	1	
14	97006-06022	BOLT	1	
15	92906-06100	WASHER, spring	1	
16	36X-83972-00	SWITCH, handle 4	1	
17	98506-05025	SCREW, pan head	1	
18	98506-05030	SCREW, pan head	1	
19	1R6-83976-01	SWITCH, handle 1	1	
20	90157-05027	SCREW, pan head	2	
21	36X-83965-00	LEVER, lock	1	
22	437-83936-00	BAND, switch cord	4	
23	5Y1-83942-00	COVER, starter	1	
24	5Y1-83941-00	LEVER, starter	1	
25	90153-06042	SCREW, hexagon	1	
26	92906-06200	WASHER, plain	1	
27	90209-10131	WASHER	1	



36X700-3350

E2

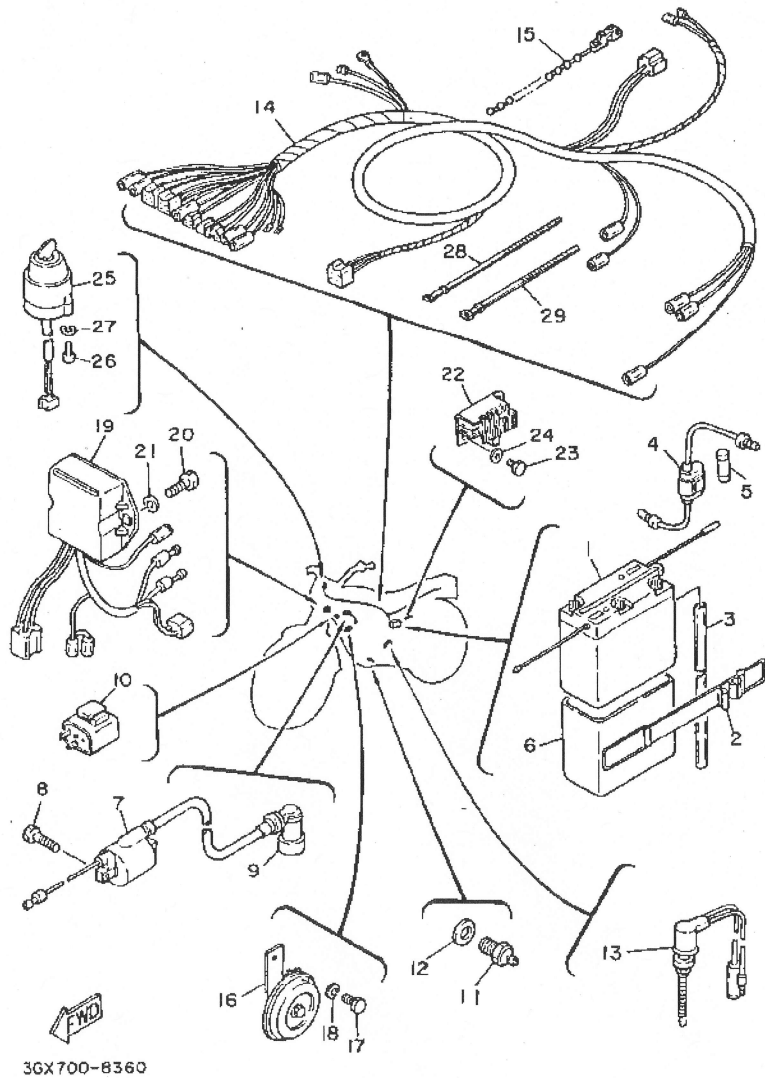

FIG. 36 ELECTRICAL 1

REF. NO.	PART NO.	DESCRIPTION	QTY	REMARKS
1	558-82110-29	BATTERY ASSY (6N48-2A-3)	1	
2	36X-82131-00	BAND, battery	1	
3	90445-08171	HOSE	1	
4	55K-82150-00	FUSE HOLDER ASSY	1	
5	116-82151-00	FUSE (10A)	2	
6	36X-82122-00	SEAT, battery	1	
7	32N-82310-M0	IGNITION COIL ASSY	1	
8	92502-06016	SCREW, pan head	2	
9	55X-82370-00	PLUG CAP ASSY	1	
10	36X-83350-10	FLASHER RELAY ASSY	1	
11	2H7-82540-00	NEUTRAL SWITCH ASSY	1	
12	90430-10027	GASKET	1	
13	2F1-82530-00	STOP SWITCH ASSY	1	
14	36X-82590-00	WIRE HARNESS ASSY	1	
15	90464-20031	CLAMP	1	
16	36X-83371-11	HORN	1	
17	97001-06012	BOLT	2	
18	92990-06100	WASHER, spring	2	
19	12V-85540-M0	C.D.I. UNIT ASSY	1	
20	97002-06016	BOLT	2	
21	92990-06100	WASHER, spring	2	
22	18A-81960-60	RECTIFIER & REGULATOR ASSY	1	
23	97001-05012	BOLT	2	
24	92901-05600	WASHER, plate	2	
25	1FE-82510-00	MAIN SWITCH ASSY	1	UR FOR AUSTRALIA
	2F5-82510-50	MAIN SWITCH ASSY	1	UR FOR OTHER COUNTRIES
26	98501-05012	SCREW, pan head	2	
27	92901-05100	WASHER, spring	2	

E3

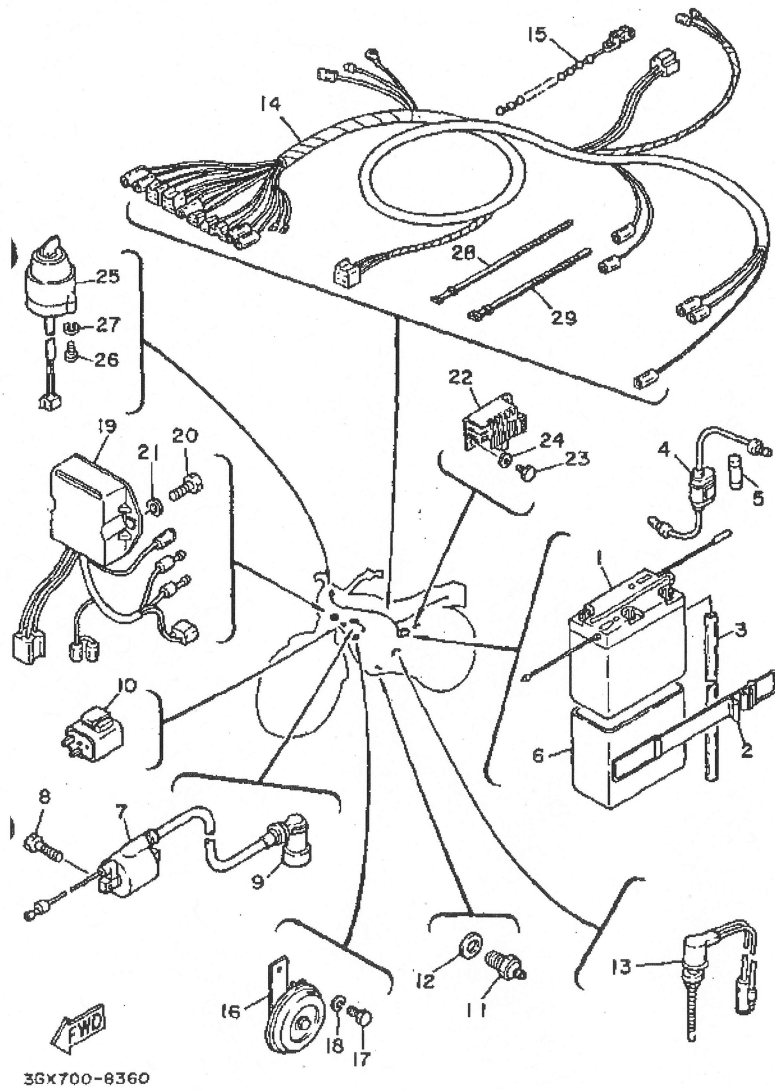

FIG. 36 ELECTRICAL 1

REF. NO.	PART NO.	DESCRIPTION	Q'TY	REMARKS
28	437-83936-10	BAND, switch cord	1	
29	437-83936-10	BAND, switch cord	3	

E4